

Orientalmotor



HP-19036-3

Stored Program Controller

EMP400 Series

OPERATING MANUAL

Thank you for purchasing an Oriental Motor product.

This Operating Manual describes product handling procedures and safety precautions.

- Please read it thoroughly to ensure safe operation.
- Always keep the manual where it is readily available.

Table of contents

1	Introduction	4	7.5	Editing the sequence program	38
2	Safety precautions	6		Checking the number of steps.....	38
3	Precautions for use	8		How to edit the program.....	39
4	Preparation.....	9		Quitting the program editing.....	45
4.1	Checking the product	9	7.6	List of messages associated with sequence program	46
4.2	How to identify the product model.....	9	8	Executing the sequence program.....	47
4.3	Names and functions of parts.....	10	8.1	How to execute a sequence program ...	47
4.4	Specifications of EMP400 Series	10	8.2	Program execution via the host controller	48
5	Installation	11		Example of sequence program execution ...	49
5.1	Location for installation	11		External stop.....	50
5.2	Installation direction	11		Alarm signal input from the driver	51
5.3	Installation method	12	8.3	Automatic program execution	52
6	Connection	13	8.4	Program execution via command	52
6.1	Assembling the connector.....	13	9	Program command.....	53
6.2	Connecting the power supply.....	14	9.1	Command input	53
6.3	Connecting the host controller (CN1)....	15	9.2	Command classification.....	54
	Connection method	15		Hardware configuration commands.....	54
	Internal input circuit.....	16		Common commands.....	55
	Internal output circuit.....	17		Operation commands.....	56
	Connection example to a host controller	18		Other commands.....	58
6.4	Connecting the driver (CN3 · CN4* ^{EMP402 only}).....	19	9.3	Special keys.....	59
	Connection method	19	9.4	List of commands.....	60
	Internal input circuit.....	20	9.5	Command details.....	62
	Internal output circuit.....	21		ABS	62
	Connection example to a driver.....	22		ACTL.....	63
6.5	Communication cable connection (CN2)	23		CJMP	63
	Connection method	23		D	64
7	Writing and editing a sequence program.....	24		DEL	65
7.1	How to write a sequence program	24		DELAY	65
7.2	Additional information on sequence program composition.....	25		DOWEL.....	65
	Sequence Program.....	25		DWNLD	66
	Parameter settings for motor operation	25		EDIT	67
7.3	Starting and exiting HyperTerminal.....	26		EEN	67
	Verifying the communication method	26		END.....	68
	How to start HyperTerminal.....	27		ENDL	68
	How to exit HyperTerminal.....	29		ETIME.....	69
7.4	Write a sequence program	29		H.....	70
	Writing a program with a line editor	29		ID.....	70
	Writing a program with a text editor	31		IN.....	71
				INC	71
				JMP.....	72
				LOOP.....	72

MHOME	73	10.4 Edit mode	92
MU	75	10.5 Teaching mode	93
OFS	76	Operation in teaching mode.....	94
OUT	76	Operation in HOME mode.....	95
PULSE	77	Operation in step execution mode.....	96
R.....	77	Operation in speed setting mode.....	98
RAMP	78	10.6 Quick chart	99
RESET	79	10.7 Error display.....	100
RTNCR.....	79	11 Troubleshooting.....	101
RUN	79	11.1 When the ALARM LED illuminates	101
S	80	Main causes of an alarm	102
SCAN.....	80	11.2 Error messages	103
SEN.....	81	12 Sample programs	108
T	82	12.1 Operation by the host controller.....	108
TIM.....	82	12.2 Speed change operation by the	
UNIT	83	host controller	108
UPLD	84	12.3 Speed change operation at a specified	
V.....	85	time.....	109
VS	85	12.4 Repeating positioning operations.....	110
		When movement amount is set in pulses...	110
10 Controlling with the operational unit ..	86	When movement amount is set in degrees...	111
10.1 Installing and connecting the		When movement amount is set in mm.....	112
operational unit	86	12.5 Conditional jump procedure	113
10.2 Basic operations	88	13 Options (sold separately)	114
Names of parts.....	88		
Switching between operation modes.....	89		
Entering and saving numeric values.....	89		
Entering the sign	90		
Entering a numeric value with a			
decimal point.....	90		
10.3 Monitor mode	91		

1 Introduction

Explains the items you should know before using this product.

■ Before using the motor unit

Only qualified personnel should work with the product. Use the product correctly after thoroughly reading the section “Safety precautions”. Also read the section “Safety precautions” in the operating manual for the motor you are using with this product.

Use a DC power supply with reinforced insulation provided on the primary and secondary sides as the power supply for the controller and I/O signals.

The product described in this manual has been designed and manufactured for use in general industrial machinery, and must not be used for any other purpose. Oriental Motor Co., Ltd. is not responsible for any damage caused through failure to observe this warning.

Oriental Motor shall not be liable for damage to on less of data resulting from the use of this product.

Duplicate copies of critically important data should be stored in a separate medium in case a mishap should occur.

■ Hazardous substances

RoHS (Directive 2002/95/EC 27Jan.2003) compliant

■ Main features

• Writing a sequence program on a PC

You can download the sequence program you have written on your PC and execute the sequence program by activating the START input from the host controller.

The sequence program can be written and modified using Windows HyperTerminal or a text editor. No special software is required.

• Superior expandability

The controller features eight and six general-purpose inputs and outputs points, respectively.

• Motor control via multiple sources

The **EMP400** Series allows motor operation either from the host controller or a PC.

The motor can be operated via the host controller by selecting 32 different sequence programs through unique combinations of different states of program selection inputs connected to the host controller and activating the START input.

The motor can also be operated via a PC by transmitting commands from a terminal program via an RS-232C communication interface.

• Easy teaching

The workpiece position can easily be adjusted using the optional **OP300** operational unit.

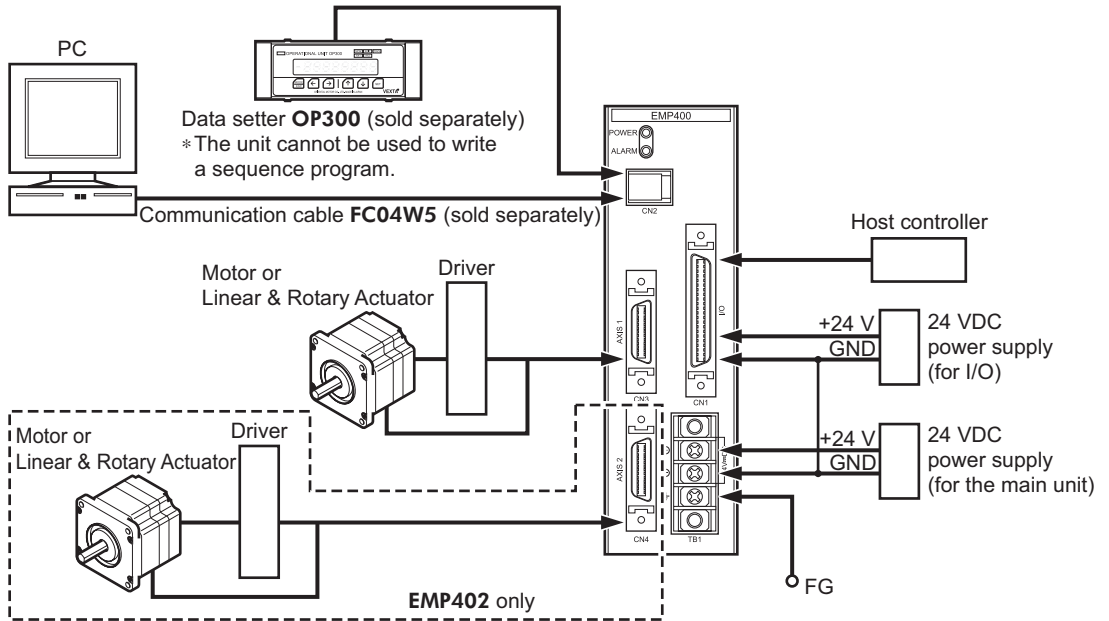

■ System configuration

A sample system configuration using the **EMP400** Series is provided below.



2 Safety precautions

The precautions described below are intended to prevent danger or injury to the user and other personnel through safe, correct use of the product. Use the product only after carefully reading and fully understanding these instructions.

 Warning	Handling the product without observing the instructions that accompany a “Warning” symbol may result in serious injury or death.
 Caution	Handling the product without observing the instructions that accompany a “Caution” symbol may result in injury or property damage.
Note	The items under this heading contain important handling instructions that the user should observe to ensure safe use of the product.
Memo	This contains information relative to the description provided in the main text.

Warning

General

- Do not use the product in explosive or corrosive environments, in the presence of flammable gases, locations subjected to splashing water, or near combustibles. Doing so may result in fire or injury.
- Assign qualified personnel the task of installing, wiring, setting, operating/controlling, and inspecting the product. Failure to do so may result in fire or injury.

Installation

- Install the controller and data setter in enclosures in order to prevent injury.
- Do not place any equipment that generates excessive heat or noise in the vicinity of the controller.
- Check and reexamine the means of ventilation if the ambient temperature of the controller exceeds 50 °C (122 °F).

Connection

- Keep the controller’s input-power voltage within the specified range to avoid fire.
- For the controller’s power, use a DC power supply with reinforced insulation on its primary and secondary sides.
- Connect the cables securely according to the wiring example in order to prevent fire.
- Do not forcibly bend, pull or pinch the power cable. Doing so may result in fire.

Operation

- Turn off the driver power in the event of a power failure, or the motor may suddenly start when the power is restored and may cause injury or damage to equipment.
- Stop the motor in the event the controller’s ALM (alarm) output is detected. Failure to do so may result in fire or damaged driver.

Repair, disassembly and modification

- Do not disassemble or modify the controller. Doing so may result in injury. Refer all such internal inspections and repairs to the branch or sales office from which you purchased the product.



General

- Do not use the controller beyond their specifications, or injury or damage to equipment may result.
- Keep your fingers and objects out of the openings in the controller, or fire may result.

Installation

- Keep the area around the controller, and data setter free of combustible materials in order to prevent fire or a burn.
- To prevent the risk of damage to equipment, leave nothing around the controller and data setter that would obstruct ventilation.

Operation

- Use a controller and driver only in the specified combination. An incorrect combination may cause a fire.
- Provide an emergency-stop device or emergency-stop circuit external to the equipment so that the entire equipment will operate safely in the event of a system failure or malfunction. Failure to do so may result in injury.
- Before supplying power to the controller, turn all output signals to the host controller to “OFF.” Otherwise, the motor may start suddenly and cause injury or damage to equipment.
- Set the speed and acceleration/deceleration rate well within the respective capacities in order to prevent abrupt load fluctuations. Failure to do so may cause the motor to misstep and the moving part to move in unexpected directions, possibly resulting in injury or equipment damage.
- Immediately when trouble has occurred, stop running and turn off the controller power. Failure to do so may result in fire or injury.

Disposal

- To dispose of the controller, disassemble it into parts and components as much as possible and dispose of individual parts/components as industrial waste.

3 Precautions for use

This section covers limitations and requirements the user should consider when using the product.

■ Power capacity

For the controller, use a DC power supply capable of supplying 24 VDC $\pm 5\%$ at 0.45 A or greater, with reinforced insulation provided on the primary and secondary sides.

■ Connecting the OP300 operational unit

Be sure to use the cable supplied with the **OP300** operational unit when connecting it to the controller. The cable comes with two ferrite cores intended for noise prevention. Do not remove these ferrite cores, since doing so may diminish noise resistance and possibly cause a malfunction.

■ Preventing electrical noise

Take the following anti-noise measures to prevent malfunction of the controller, driver, and motor due to external noise:

- Wiring the I/O cable

For I/O cables, use a shielded cables with connectors (sold separately).

Minimize the length of the I/O cable.

Wire the I/O cables by maintaining a minimum distance of 300 mm (11.8 in.) from the inductive loads of electromagnetic relays, etc., as well as the power lines (the power supply and motor, etc.). Do not wire the I/O cables in the same duct or pipe in which power lines are wired.

- Connecting mains filter for power supply line

Connect a noise filter on the input side of the DC power supply to prevent external noise from being transmitted to the controller via the power supply line.

Ground the noise filter's contact terminal using a cable of AWG18 (0.75 mm²) or more in diameter. The use of a cable smaller than AWG18 may cause heat generation.

4 Preparation

This section explains the items you must check, as well as the names and functions of parts and key specifications of the product.

4.1 Checking the product

Upon opening the package, verify that the items listed below are included.

Report any missing or damaged items to the branch or sales office from which you purchased the product.

• **EMP400** Series controller 1 unit

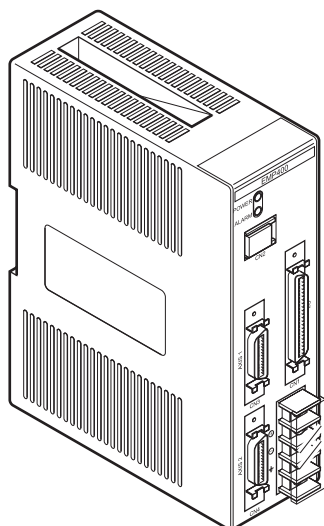

• I/O connector (50 pins) 1 set

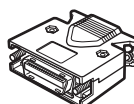

*EMP401-2 and EMP402-2 only

• AXIS connector (26 pins) **EMP401-2** 1 set
EMP402-2 2 sets

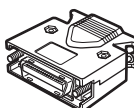

*EMP401-2 and EMP402-2 only

• Operating manual 1 copy

Model		Connector included (Molex)	Equivalent (Sumitomo 3M Limited)
I/O connector (50 pins)	Connector	54306-5019	10150-3000VE
	Case	54331-0501	10350-52A0-008
AXIS connector (26 pins)	Connector	54306-2619	10126-3000VE
	Case	54331-0261	10326-52A0-008

4.2 How to identify the product model

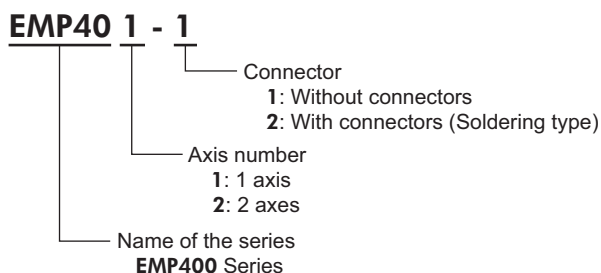

4.3 Names and functions of parts

This section covers the names and functions of parts in the controller.

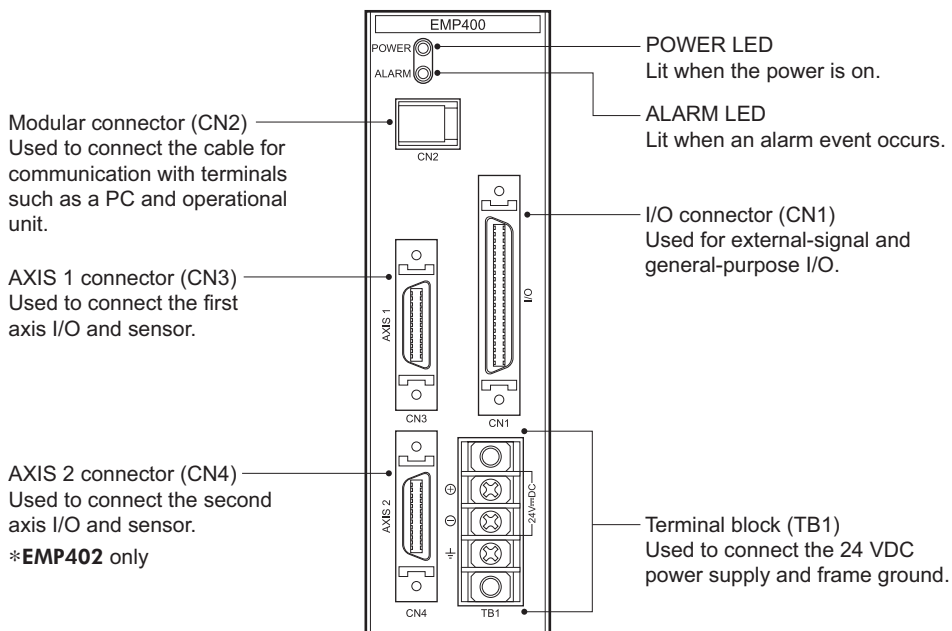

4.4 Specifications of EMP400 Series

Control axis number	1 or 2
Number of sequence programs	32 (sequence programs 0 through 31) The sequence program 99 is a CONFIG program.
Number of program lines	1000 lines
Parameters	Starting speed: 10 to 200 kHz (1 Hz increments) Operating speed: 10 to 200 kHz (1 Hz increments) Acceleration rate: 0.5 to 1000 ms/kHz (0.1 ms/kHz increments) Acceleration mode: Linear acceleration/deceleration, jerk limit control Pulse count: ±16,777,215 pulses
Pulse range	-8,388,608 to +8,388,607 pulses
Operation mode	Positioning operation (2-axis linear interpolation operation available with EMP402 only) Continuous operation Mechanical home seeking operation
Mode for mechanical home seeking	3-sensor mode (high-speed home seeking) 2-sensor mode (constant-speed home seeking) Mechanical home seeking is possible via TIM. or SLIT input
Data transmission format	RS-232C based (3-wire)
General-purpose input	8 points, photocoupler inputs
General-purpose output	6 points, open-collector outputs, +5 to 24 VDC, 25 mA or less a point
Power supply voltage	24 VDC ±5% current consumption at 0.45 A
Weight	0.26 Kg (0.58 lb.)

5 Installation

This section covers the conditions and method for controller installation.

5.1 Location for installation

This controller is designed and manufactured for installation in equipment.

Install them in a well-ventilated location that provides easy access for inspection. The location must also satisfy the following conditions:

- Inside an enclosure that is installed indoors (provide vent holes)
- Operating ambient temperature 0 to +50 °C (+32 to +122 °F) (non-freezing)
- Operating ambient humidity 20 to 85% (non-condensing)
- Area that is free of explosive atmosphere or toxic gas (such as sulfuric gas) or liquid
- Area not exposed to direct sun
- Area free of excessive amount dust, iron particles or the like
- Area not subject to splashing water (rains, water droplets), oil (oil droplets) or other liquids
- Area free of excessive salt
- Area not subject to continuous vibration or excessive shocks
- Area free of excessive electromagnetic noise (from welders, power machinery, etc.)
- Area free of radioactive materials, magnetic fields or vacuum

5.2 Installation direction

When installing the controller inside an enclosure, place it in a vertical orientation by mounting it on a DIN rail or securing it with screws through the two mounting holes provided on the controller.

There must be a clearance of at least 25 mm (0.98 in.) and 50 mm (1.97 in.) in the horizontal and vertical directions, respectively, between the controller and the enclosure or other equipment.

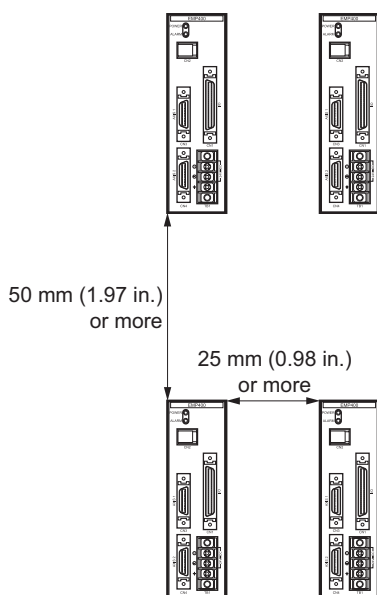

5.3 Installation method

Mount the controller on a DIN rail. In case the DIN rail produces significant vibrations, mount the controller on an appropriate metal plate.

■ Mounting the controller on a DIN rail

Use a DIN rail of 35 mm (1.38 in.) in width. Use the end plates to secure the controller mounted on the DIN rail.

1. Engage the hook on the back of the controller over the DIN rail by pulling down the controller's DIN lever, and push the controller until the DIN lever locks in place.
2. Secure each end of the controller using the end plates.

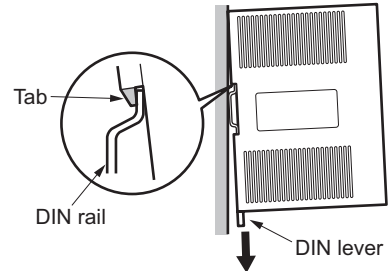

■ Installing the controller with screws

Install the controller on a metal plate and secure it using two screws (M3 or M4, two pcs.: not supplied). There should be no gap between the controller and plate.

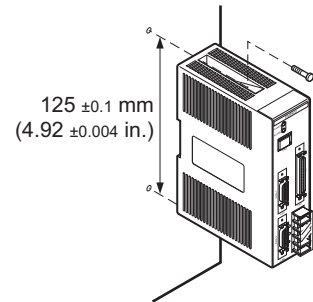

■ Removing the controller from the DIN rail

1. Use a flat-head screwdriver to pull down the DIN lever until it locks in place. Pull the DIN lever with a force of 10 to 20 N (2.2 to 4.41 lb.). Applying excessive force may damage the DIN lever.
2. Raise the controller upward to remove from the DIN rail.

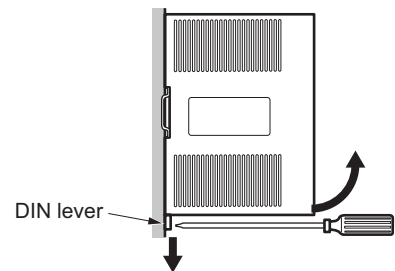

6 Connection

This section covers the methods for connecting the power, driver, host controller and other units to the **EMP400** Series controller, as well as the grounding method, I/O circuits and a connection example.

6.1 Assembling the connector

Solder-type connectors are supplied with the **EMP401-2** and **EMP402-2** Series controllers.

Solder the host controller cable for the I/O connector and the driver cable for the AXIS connector.

The following figure shows the pin arrangement of the connector. (Viewed from the soldering side)

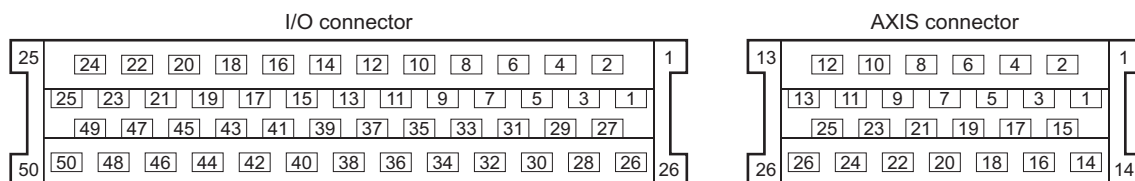

1. Solder the cable to the connector pins.
The cable is not included in the package. Use a multi-core, overall-shielded, twisted-pair cable of AWG28 (0.08 mm²) or more in diameter.
2. Place the screws (M2.5, two pcs.) supplied with the connector in the bottom case.
Place the screws so that their washers align with the indents in the case and the spring washers sit on the outside of the case.
3. Place the connector with the cable in the bottom case and screw the cable mounting bracket.
Tightening torque: 0.3 to 0.35 N·m (42.6 to 49.7 oz-in)
4. Place the top case and assemble the top and bottom case using the supplied screws (M2.5, two pcs.) with supplied hexagonal nuts.
Tightening torque: 0.5 to 0.55 N·m (71 to 78.1 oz-in)

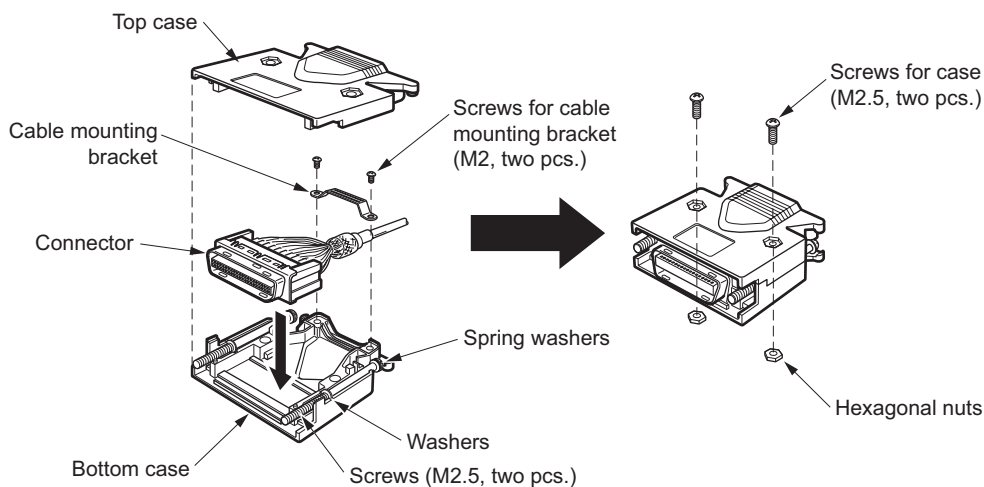

6.2 Connecting the power supply

The controller's power supply is connected to the TB1 terminals. In addition to the power supply terminals, TB1 has a frame ground (FG) terminal to prevent malfunctions caused by external noise. The power supply provides a voltage of 24 VDC \pm 5% with current consumption of 0.45 A or less. The current consumption level includes the current supplied to the operational unit. Use insulated round crimp terminals for power cable and grounding wires.

Note The power supply should be designed to provide ample capacity. Insufficient power capacity may cause an error in the controller operation.

1. Remove the terminal cover from TB1.
2. Remove the positive and negative terminal screws, then connect the 24 VDC power cable.

Verify that the connection has the proper polarity.

Note For the power cable, use the cable of AWG20 (0.5 mm^2) or more in diameter. Any cable with a smaller diameter may cause heat generation.

3. Tighten terminal screws at a tightening torque of 0.5 N·m (71 oz-in).
4. Remove the FG terminal screws and connect the grounding wire.

Note For the grounding wire, use the cable of AWG18 (0.75 mm^2) or more in diameter. Any cable with a smaller diameter may cause heat generation.

5. Tighten terminal screws at a tightening torque of 0.5 N·m (71 oz-in).
6. Secure the grounding wire connected to the FG terminal to the ground point, using screws with a crow washer.

The above grounding wire should be grounded at one point together with the grounding wire connected to the driver's protective earth terminal.

7. Place the terminal cover on TB1.

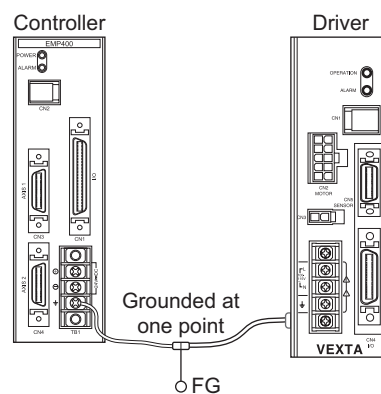
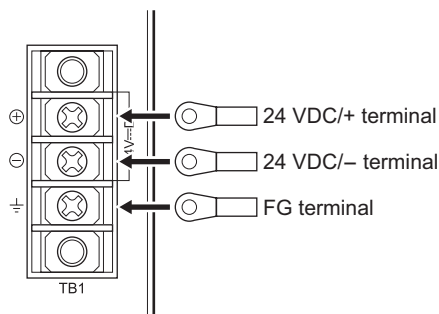

■ TB1 signals

Symbol	Signal	Description
⊕	+24 V power	Input terminal of the power supply
⊖	GND	Ground of the power supply
⊥	FG	Frame ground

6.3 Connecting the host controller (CN1)

Connection method

Use the I/O connector (50 pins) for connection with the host controller.

Plug the I/O connector into CN1 and tighten the screw.

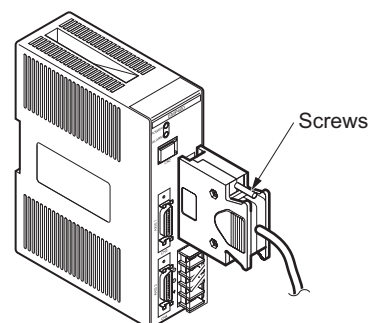

■ CN1 (I/O) signal table

Pin No.	Signal	Description
1	–	No connection
2	E-STOP input	External stop ^{*1}
3	START input	Execution of a sequence program
4	S-STOP input	Operation stop
5	–	No connection
6	–	No connection
7	+COM input	Power supply for I/O (+24 V) ^{*2}
8	IN1 input	General-purpose input
9	IN2 input	
10	IN3 input	
11	IN4 input	
12	IN5 input	
13	IN6 input	
14	IN7 input	
15	IN8 input	
16	+COM input	Power supply for I/O (+24 V) ^{*2}
17	OUT1 output	General-purpose output
18	OUT2 output	
19	OUT3 output	
20	OUT4 output	
21	OUT5 output	
22	OUT6 output	
23	–	No connection
24	–	No connection
25	–COM input	Power supply for I/O (GND) ^{*2}

Pin No.	Signal	Description
26	–	No connection
27	ALM output	Alarm
28	–	No connection
29	MOVE output	During pulse generation
30	–	No connection
31	READY output	READY to accept START input
32	+COM input	Power supply for I/O (+24 V) ^{*2}
33	M0 input	Selection of sequence program number
34	M1 input	
35	M2 input	
36	M3 input	
37	M4 input	
38	–	No connection
39	–	No connection
40	–	No connection
41	–	No connection
42	–	No connection
43	–	No connection
44	–	No connection
45	–	No connection
46	–	No connection
47	–	No connection
48	–	No connection
49	END output	Positioning complete
50	–COM input	Power supply for I/O (GND) ^{*2}

*1 The E-STOP input is at normally close. (The state of the contact is given when the photocoupler is turned off.)

*2 +COM and –COM inputs are shared internally.

Internal input circuit

Memo | The signal state represents the “ON: Carrying current” or “OFF: Not carrying current” state of the internal photocoupler rather than the voltage level of the signal.

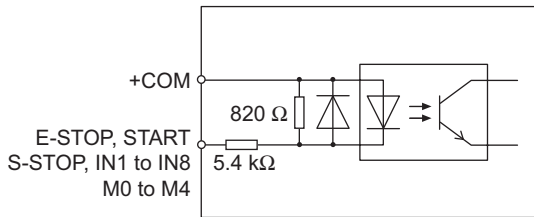

- **E-STOP input**

This terminal is used to input the external stop signal.

The E-STOP input is a normally close. Input is enabled when the E-STOP is turned off, immediately stopping pulse output and stopping the motor. The sequence program stops, also.

In the normal state, be sure to connect the E-STOP input to GND to keep it on.

Memo | Only when the E-STOP input is turned on immediately after power on sequence program 99 will be executed.

- **START input**

This terminal is used to input the signal for starting the sequence program.

The sequence program is executed once the START input is turned on.

- **S-STOP input**

This terminal is used to input the signal for stopping the operation.

If the S-STOP input is turned on while the motor is operating, the motor will decelerate to a stop.

When the S-STOP input turns on, the sequence program will stop.

Once operation resumes, the sequence program will start over from the beginning.

- **IN1 to IN8 inputs**

General-purpose input terminals

- **M0 to M4 inputs**

Terminals for choosing the sequence program to be used through unique combinations of the M0 to M4 input states.

For more information about the selection of sequence programs through combinations of M0 to M4 input states, see section 8.2 “Program execution via the host controller” on p.48.

Internal output circuit

Memo | The signal state indicates the “ON: current supplied” or “OFF: current not supplied” status of the photocoupler inside a host controller rather than the voltage level of the signal.

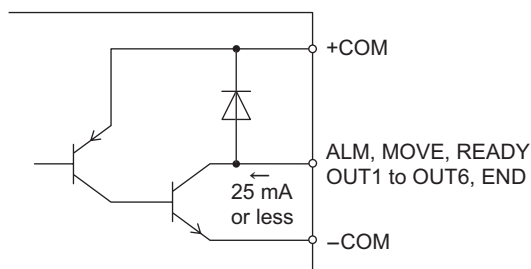

• ALM output

The ALM output is turned on when the E-STOP input is turned off, there is an error alarm in the controller.

Once the problem’s cause is eliminated, the ALM output is cancelled automatically. For more information on the causes and handling of alarms, see section 11.1 “When the ALARM LED illuminates” on p.101.

The output logic may be switched between normally open and normally close via command inputs. (Set to “normally close” at the time of power on.)

- Note** |
- If a driver alarm signal is input, an alarm will be output when a motor operation command (INC, ABS, MHOME or SCAN) is executed.
 - If a +LS or –LS signal is input, an alarm will be output when a motor operation command (INC or ABS) is executed. (Executing a MHOME or SCAN command will cause the motor to pull out of the LS range.)

• MOVE output

The MOVE output is turned on during pulse output.

- Note** | If the rotational direction is switched during mechanical home seeking, the pulse output will be cut off and the MOVE output will turn off.

• READY output

The READY output is turned on when the controller is ready to accept the START input.

The READY output is turned off while the sequence program is being executed or modified.

• OUT1 to OUT6 outputs

General-purpose outputs.

All of the outputs will turn off when a sequence program is started.

• END output

One-shot output will be performed after a positioning operation.

The amount of output time can be changed via command input. (Set to 10 ms at the time of power on.)

If END input from the driver is set to “used” via command input, pulse output from the controller will cease. When the END input from the driver turns on, END output also turns on.

Connection example to a host controller

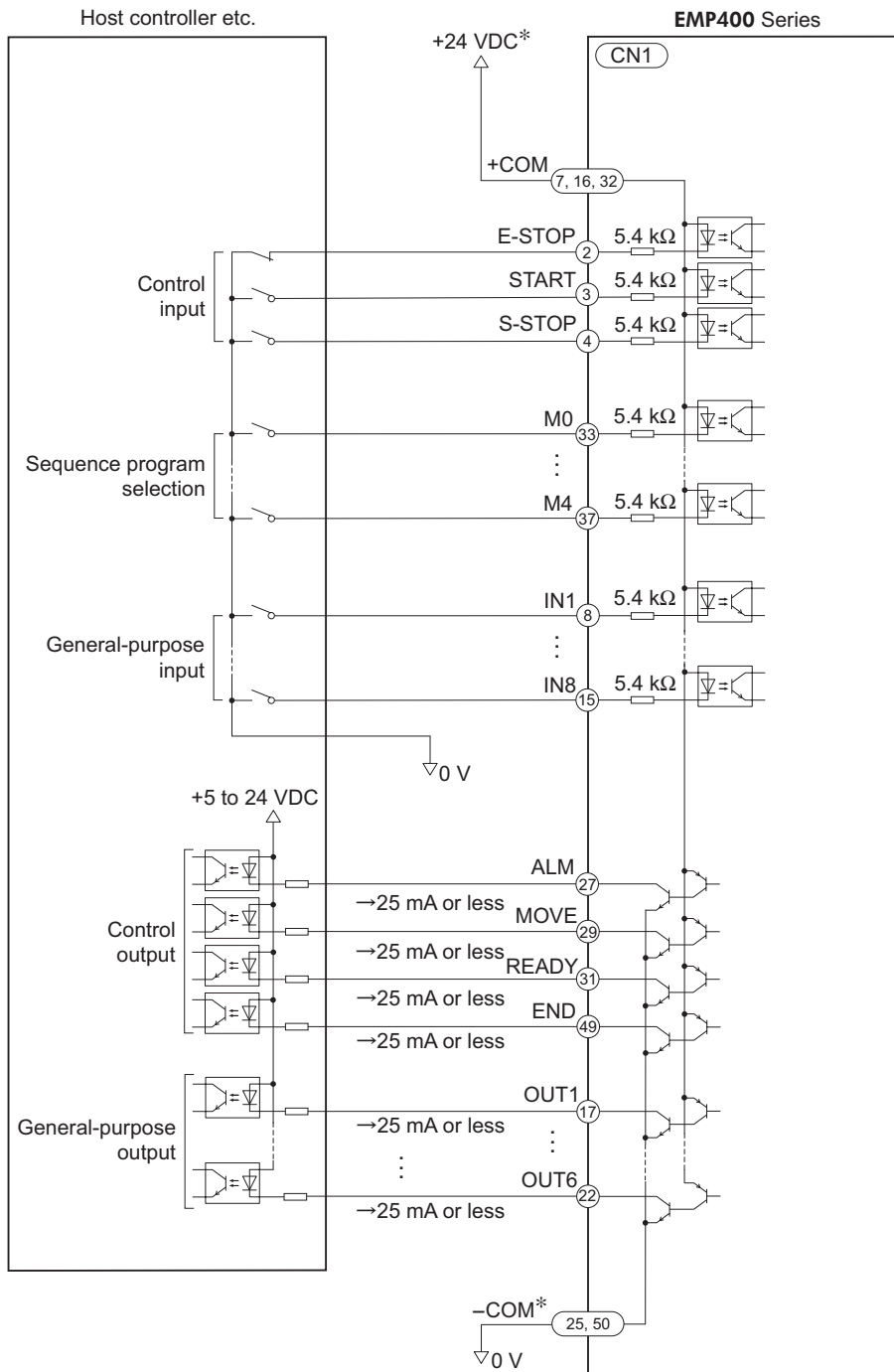

* When the I/O signals from CN1 are used, connect 24 VDC to the +COM and -COM input terminals separately from the power supply input.

6.4 Connecting the driver (CN3 · CN4*EMP402 only)

Connection method

Use the AXIS connector (26 pins) for connection with the driver.
Plug the AXIS connectors for the first- and second-axis drivers into CN3 and CN4, respectively, and tighten them with screws.

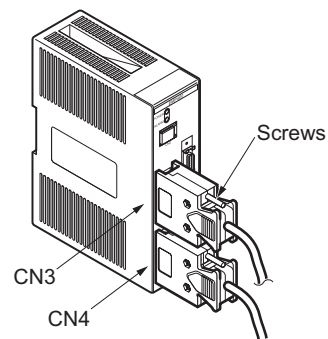

■ CN3-CN4 signal table

Pin No.	Signal	Description	Pin No.	Signal	Description
1	+CW-P output (+PULSE output)	CW pulse (pulse)	14	–	No connection
2	–CW-P output (–PULSE output)	CW pulse (pulse)	15	–	No connection
3	+CCW-P output (+DIR. output)	CCW pulse (Direction of rotation)	16	+CCR output	Counter-clear
4	–CCW-P output (–DIR. output)	CCW pulse (Direction of rotation)	17	–CCR output	Counter-clear
5	END input	END signal from driver	18	GND	GND signal from driver
6	TIM. input	Timing signal from driver	19	–	No connection
7	ALM input	Alarm signal from driver	20	–	No connection
8	+LS input	CW limit sensor	21	–	No connection
9	–LS input	CCW limit sensor	22	–	No connection
10	HOMELS input	Home limit sensor	23	–	No connection
11	SLIT input	Slit sensor	24	–	No connection
12	+12 V output	Power supply terminal for sensor (140 mA max.)	25	+5 V output	Power supply terminal for timing signal (20 mA max.)
13	GND	GND for sensor	26	GND	GND for timing signal

- Outputs to driver (1 to 4 and 16, 17 pins)
Inputs from driver (5 to 7 and 18 pins)
Sensor (8 to 13 pins)
For timing signals (25 and 26 pins)
- Shown in parentheses is the information for 1-pulse output mode.
Pins 25 and 50 of CN1 and pins 13, 18 and 26 of CN3/CN4 are connected internally.

Internal input circuit

Memo | The signal state indicates the “ON: current supplied” or “OFF: current not supplied” state of the internal photocoupler rather than the voltage level of the signal.

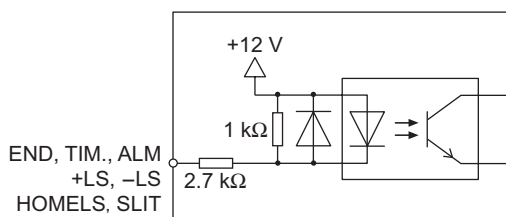

- END input

This terminal is used to input the END signal output from the driver at the end of operation. This terminal should be connected when using the *αSTEP* or servo motor.

The END signal is enabled or disabled via command input. (Set to “enabled” at the time of power on.)

- TIM. input

This terminal is used to input the timing signal from the driver.

When mechanical home is detected in mechanical home seeking mode, an accurate home position can be found by using this signal with the HOMELS input or the HOMELS input/SLIT input by connecting them with an AND logic operator.

- ALM input

This terminal is used to input the alarm signal from the driver. (The driver’s alarm outputs may either be at normally open or normally close, depending on the model.)

If an alarm-signal input is fed while the motor is in operation, the motor will decelerate to a stop and the sequence program will stop also.

No pulse can be output while alarm signal inputs are being fed, although any command not associated with pulse output can be executed.

The input logic may be switched between normally open and normally close via command inputs. (Set to “normally close” at the time of power on.)

- +LS and –LS inputs

This terminal is used to input signals from +LS and –LS.

If the LS input is turned on during pulse output, the motor will stop immediately. However, mechanical home seeking will continue even if the LS input is turned on.

The input logic may be switched between normally open and normally close via command inputs. (Set to “normally open” at the time of power on.)

Note | Note that two different input logics cannot be set for the +LS and –LS inputs, respectively.

- HOMELS input

This terminal is used to input signals from HOMELS when performing high-speed home seeking using 3-sensors.

The input logic may be switched between normally open and normally close via command inputs. (Set to “normally open” at the time of power on.)

- **SLIT input**

This terminal is connected when using a motorized linear slides with a slit sensor.

An accurate home position can be found by using this signal with the HOMELS input or the HOMELS input/TIM. input by connecting them with an AND logic operator.

The input logic may be switched between normally open and normally close via command inputs. (Set to “normally open” at the time of power on.)

Internal output circuit

Memo | The signal state indicates the “ON: current supplied” or “OFF: current not supplied” status of the photocoupler inside a driver rather than the voltage level of the signal.

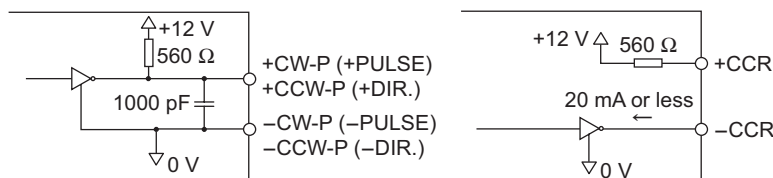

- **±CW-P (±PULSE) output, ±CCW-P (±DIR.) output**

These terminals are used to output pulses.

Information in parentheses is for 1-pulse output mode. In the 1-pulse output mode, the motor will rotate in the CW direction with the DIR. output turned on and in the CCW direction with the DIR. output turned off.

The output mode may be switched between 1-pulse and 2-pulse modes via the PULSE command. (Set to “2-pulse mode” at the time of power on.)

- **±CCR output**

These terminals are used to output counter clear signals for resetting the counter in the driver.

These terminals should be connected when a servo motor is used.

The circuit will generate CCR outputs in any of the following situations (output width 500 μs):

- The E-STOP input is turned off while the motor is in operation
- While mechanical home seeking is in progress
- When the motor has pulled out from the limit sensor during continuous operation
- When an alarm event has caused the operation to stop immediately
- When the power is turned on or the RESET command is input

Connection example to a driver

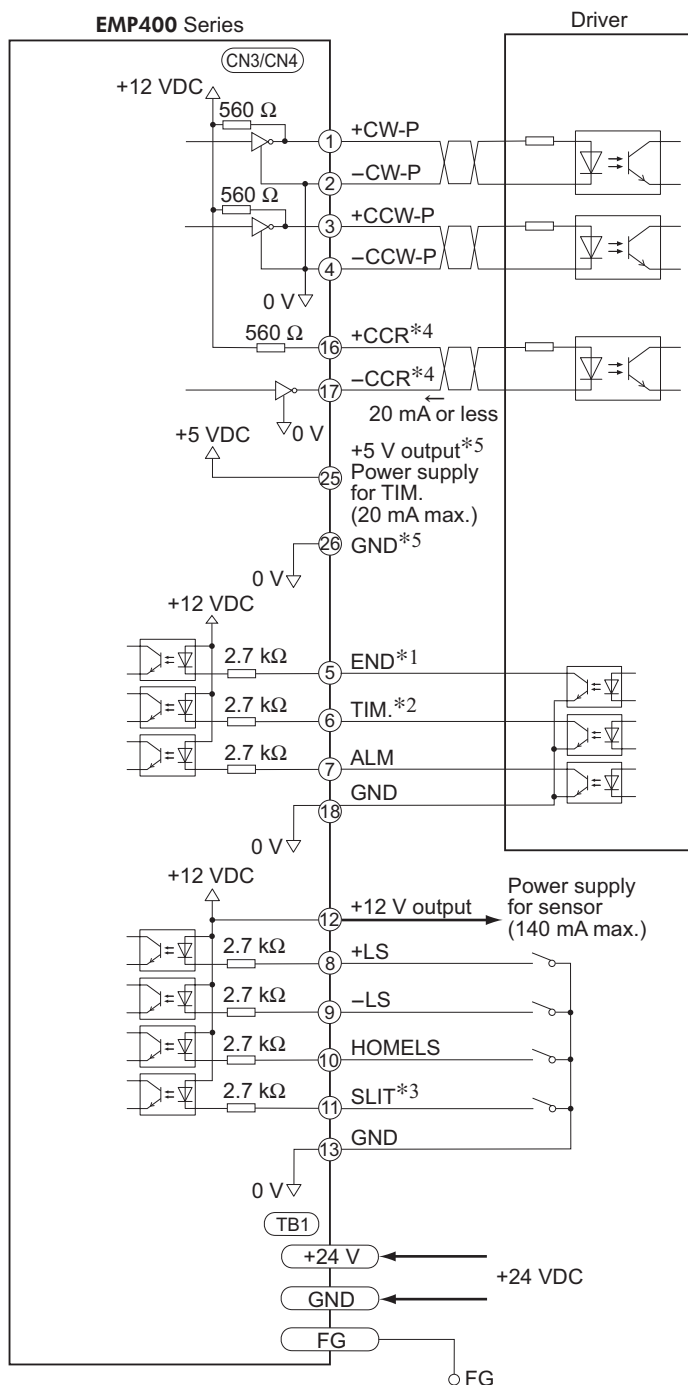

- *1 Connect the END input (5 pin) when using an *α*STEP or servo motor.
- *2 Do not connect the TIM. input (6 pin) when using a servo motor.
- *3 Connect the SLIT input (11 pin) when using a motorized linear slides with a slit sensor.
- *4 Connect the CCR output (16 and 17 pins) when using a servo motor.
- *5 Connect the timing-signal power supply (25 and 26 pins) to the driver (1 and 2 pins) when using the TIM. output with an *α*STEP AS Series motor.

6.5 Communication cable connection (CN2)

Connection method

Communication cables are used to connect a PC and the operational unit.

Plug the communication cable connector into CN2.

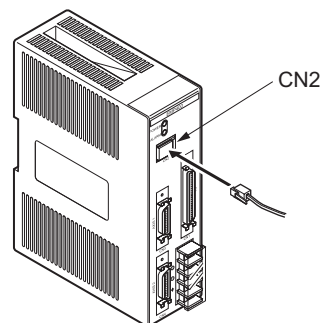

7 Writing and editing a sequence program

This section covers how to write a sequence program and edit an existing sequence program.

7.1 How to write a sequence program

The sequence program contains the method of motor operation as well as speed settings and other parameters.

Once the sequence program is started, the motor will execute the commands contained in the sequence program according to a specified order.

The sequence program is stored in the controller memory.

A sequence program can be written using one of the following two methods:

■ Using a line editor

Input commands using a line editor.

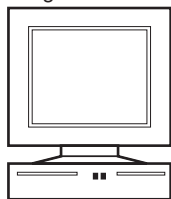

Send a command at each press of the  key.

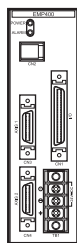

1. Connect the controller with a PC.
See section 7.3 “Starting and exiting HyperTerminal” on p.26.
2. Use a line editor to save commands to the controller in real time.
Each time the Enter key is pressed following command input, the command is sent to the controller.
See section “Writing a program with a line editor” on p.29.

■ Using a text editor

Write a sequence program using a text editor.



Download the sequence program.

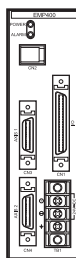

1. Write a sequence program using a text editor, then save it in text format.
See section “Writing a program with a text editor” on p.31.
2. Connect the controller with a PC.
See section 7.3 “Starting and exiting HyperTerminal” on p.26.
3. Download the sequence program in the text-format file to the controller.
See section “Downloading a sequence program” on p.33.

7.2 Additional information on sequence program composition

Sequence Program

- A sequence program is composed of commands to the controller and parameters.
- Type in alphanumeric characters (case-insensitive) to define commands and parameters for the sequence program.
- The character string containing a command and parameters is called “line.” One line can only contain one command.

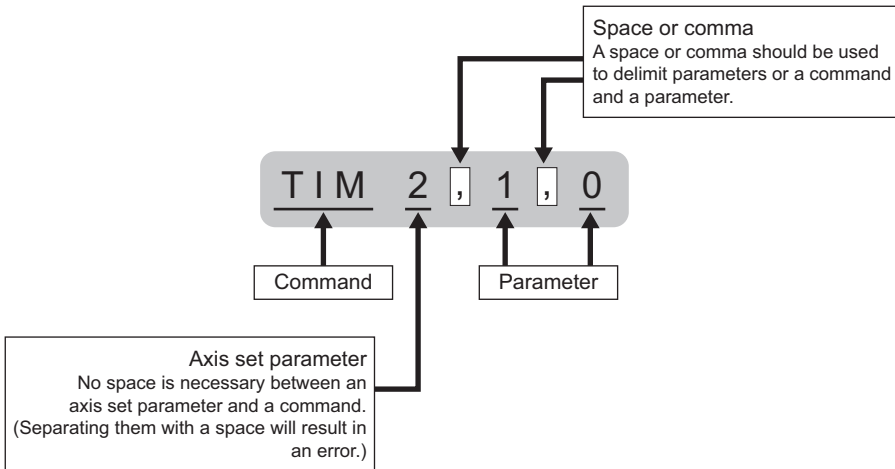

A maximum of 32 sequence programs can be created, from sequence program numbers 0 through 31. Additionally, sequence program number 99 can be written as an automatically executable program. (See section 8.3 “Automatic program execution” on p.52.)

A total of 1000 lines can be configured for these 33 sequence programs.

Example 1: 125 lines × 8 sequence programs = 1000 lines

Example 2: 500 lines × 2 sequence programs = 1000 lines

Parameter settings for motor operation

Correct settings for sensors and drivers should be defined before operating the motor.

Settings are required for the following parameters. For further details, see “Hardware configuration commands” on p.54.

- Pulse output mode setting PULSE command
- ID setting ID command
- Setting for +/-LS input, HOMELS input or SLIT input logic ACTL command
- Input logic setting for alarm input from the driver ACTL command
- Setting for alarm output logic ACTL command
- Home detection method setting SEN command
- END input usage EEN command
- TIM. input usage TIM command
- SLIT input usage TIM command
- Unit-value setting UNIT command

7.3 Starting and exiting HyperTerminal

Verifying the communication method

1. Start the PC and open “System” in the control panel.
The System window then appears.
2. Select the “Device Manager” tab.
The Device window then appears.

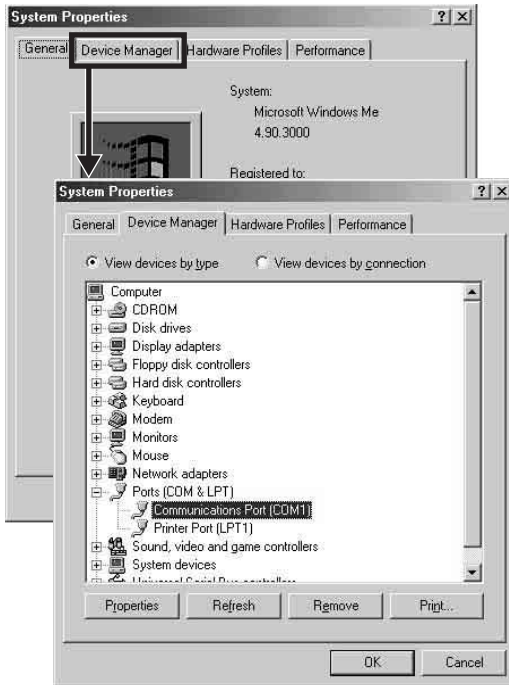

3. Verify that there is “Communication Port (COM*)” under “Port.”
If there is no “Communication Port (COM*),” read the operating manual for your PC and set up a serial communication function.

How to start HyperTerminal

1. Switch off the power to the controller.
2. Connect the controller's CN2 with your PC using the optional **FC04W5** communication cable (purchased separately).
3. Start the PC.
4. Click on the "Start," "Program," "Accessories," "Communication" and "HyperTerminal" icons to start HyperTerminal.

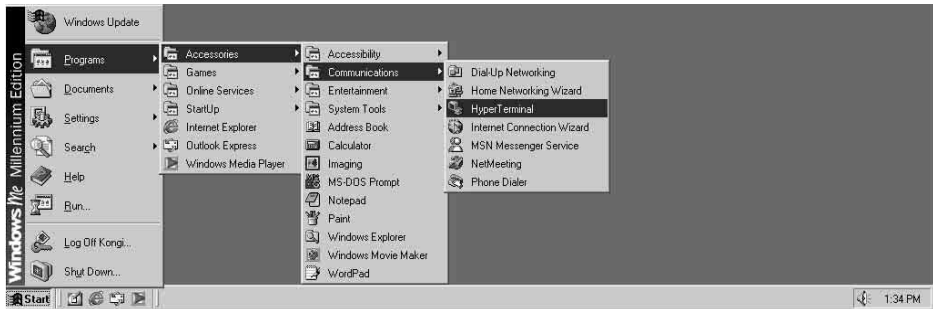

5. Type in a name for the connection (e.g. **EMP401**), then select an icon and click "OK."

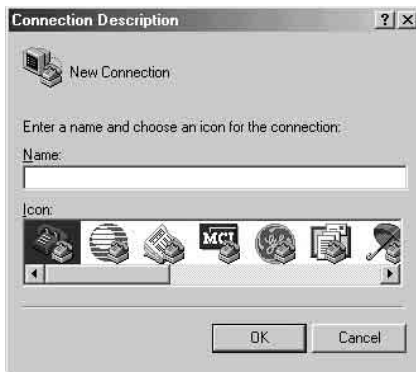

6. In a typical connection method you may select the communication port you have previously verified as described in section "Verifying the communication method," on p.26 and click "OK."



7. Set the properties as follows and click “OK.”

- Bits per second: 9600 bps
- Data bit: 8
- Parity: None
- Stop bit: 1
- Flow control: None

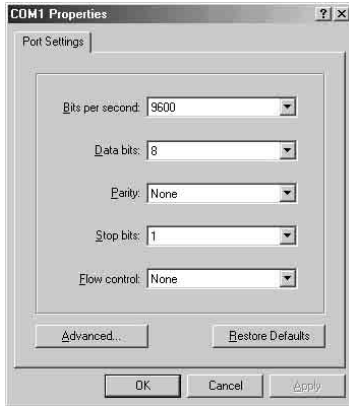

Note | The connection method may vary, depending on the PC.
For details, see the operating manual for your PC.

8. Power on the controller.

The HyperTerminal screen indicates that the controller has started up.

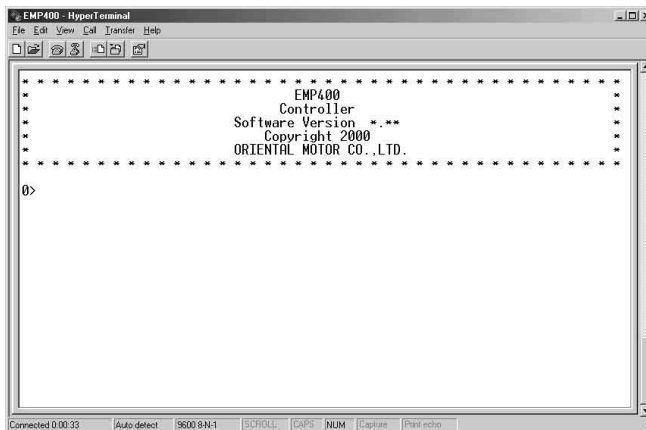

Memo | The connection settings are required only before the initial connection.

How to exit HyperTerminal

1. Exit HyperTerminal.

A message appears, asking if you want to disconnect.



2. Click “Yes.”

A message appears, asking if you want to save the settings.

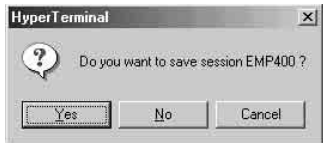

3. Click “Yes.”

The settings are saved and an icon is created.



EMP401

Memo | Saving of the settings is required only after the initial connection.
For subsequent connections, you may start HyperTerminal simply by double-clicking the icon.

7.4 Write a sequence program

Writing a program with a line editor

HyperTerminal (Windows application) can be used as a line editor to write a sequence program.

While using HyperTerminal, command inputs to HyperTerminal are saved to the controller in real time.

1. See section 7.3 “Starting and exiting HyperTerminal” on p.26, to connect the controller with your PC and start HyperTerminal.

2. Type in “EDIT *” (* represents a sequence program).
 Insert a space between “EDIT” and the sequence program number.
 Once the entry is made, a message “Empty... Direct Insert Mode” appears, indicating that the sequence program is empty. You can now write a new sequence program.

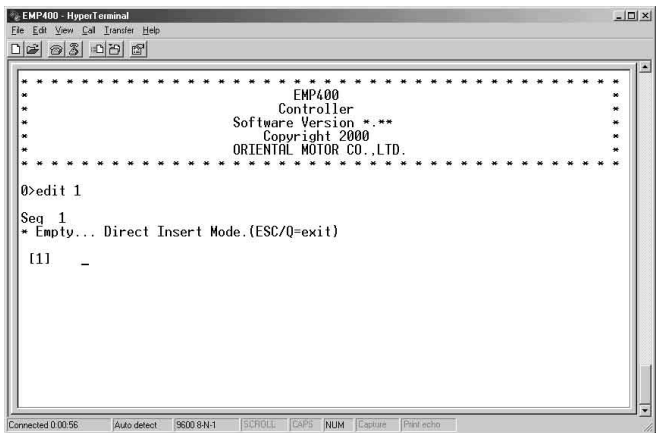

3. See Chapter 9 “Program command” on p.53, to enter commands and parameters in order to write a sequence program.
 The example sequence program below shows the sequence program number 1 specifying a starting speed of 100 Hz, operating speed of 3000 Hz, distance of 6000 pulses and + (CW) direction.

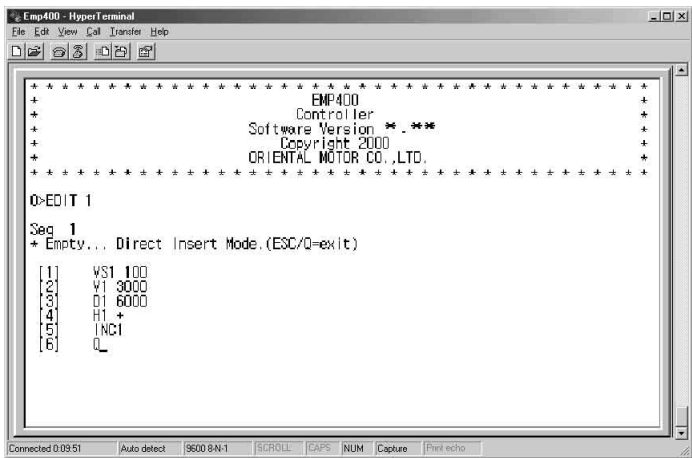

Memo | To complete the writing of a sequence program, type in “Q” or press the ESC key.

■ When an error message appears

An error message is displayed if any invalid command or parameter is entered while the sequence program is being created.

If an error message appears, see section 7.6 “List of messages associated with sequence program” on p.46, for the appropriate corrective action.

Writing a program with a text editor

A sequence program may be written using a text editor on your PC.

The sequence program should then be saved in text format for downloading to the controller via HyperTerminal’s transmission function.

The downloaded sequence program will be saved in the controller memory.

The sequence program saved in the controller may also be uploaded to a PC via HyperTerminal’s transmission function and saved in text format.

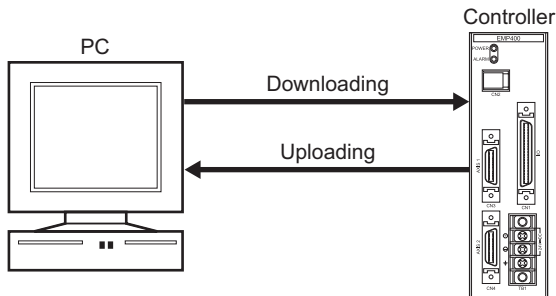

■ How to write a program

There is a set of requirements that must be satisfied when writing a sequence program using a text editor. These requirements are explained in the following example of sequence program composition.

1. Start a text editor.
2. Write a sequence program by meeting the requirements explained below.
Type in alphanumeric characters.

Memo | Up to 80 characters (including the characters of comments) may be entered for each line.

[Requirements]

- *1 The sequence program should start with “Seq*” (* represents a sequence program number).
Enter a space between “Seq” and the sequence program number.
- *2 Enter the line number in brackets “[].”
- *3 No more than one command can be entered into a single line.
- *4 Following the last line of the sequence program, be sure to press the Enter key at least once.
- *5 One text file can contain more than one sequence program.
- *6 The line number may be omitted. A space may be entered.
- *7 Any character string entered following “ ; ” will be a comment. The comment will not be saved in the controller.

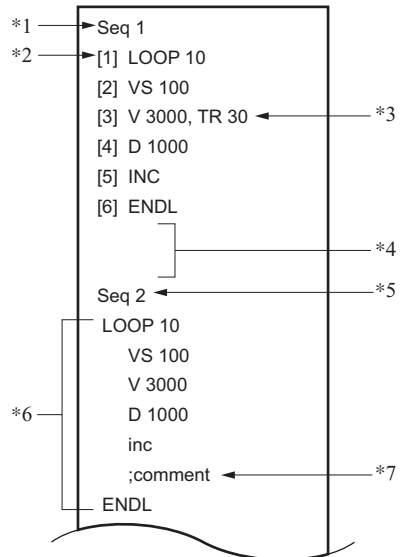

3. Save the created sequence program in text format.

Always add the “.txt” extension to the text file name. Downloading the file you created and saved in text format in Step 2 to the controller and then uploading it to a PC will result in the following:

[Results]

- *3 An error has occurred, since more than one command was entered into one step.
- *4 Blank steps have been deleted.
- *6 An [n] representing the line number has been added. A space has been deleted.
- *7 A comment has been deleted.

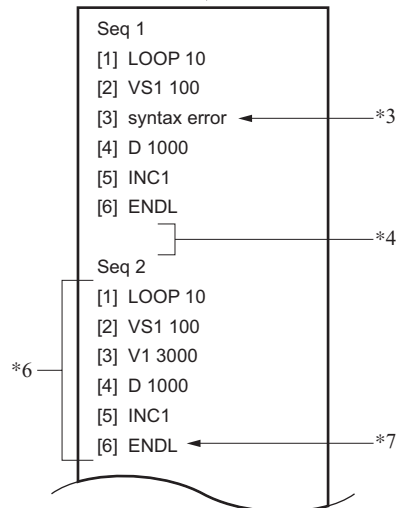

6. Select a sequence program for uploading to the PC.

Type in a desired number from among “0” through “31” and “99” to specify one sequence program number, or type in “A” to upload all of the sequence programs. Then, press the Enter key. A message appears, prompting you to select text capture (Start “TEXT CAPTURE”).

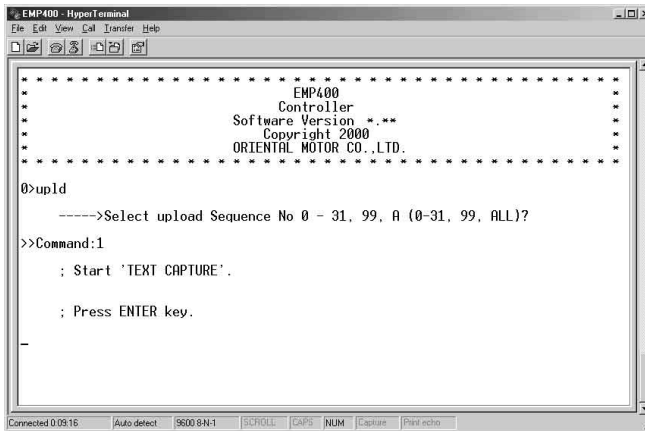

7. Select “Capture Text” from the “Transfer” menu of HyperTerminal. The Capture Text window appears.

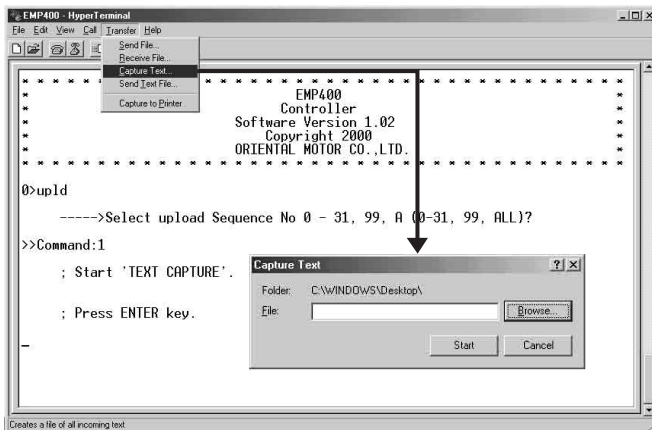

8. Click on “Browse.”

A window appears to specify the file name and the folder under which to save the file.

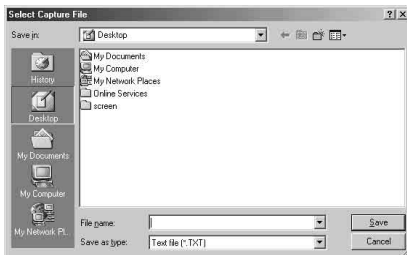

9. Specify the text file saved in step 3 and click on “Save.” The Capture Text window appears.

10. Click on “Start.”
The HyperTerminal screen appears.
11. Press the Enter key.
The controller begins uploading the sequence program.
Once uploading is complete, a message (End “TEXT CAPTURE”) appears.

Note | Do not use the keyboard while the sequence program is being uploaded.
Doing so may result in an upload error.

```

; Start 'TEXT CAPTURE'.
; Press ENTER key.

Seq 1
[1] VS1 100
[2] V1 3000
[3] D1 6000
[4] H1 +
[5] INC1

; Completed.
; End 'TEXT CAPTURE'.
; Press ENTER key.

```

12. Select “Capture Text” from the “Transfer” menu of HyperTerminal, then select “Stop.”
This ends the Text Capture function.
13. Press the Enter key.
The “0>” command prompt is displayed.
14. Open the text file you saved and check to see that the sequence program has been uploaded correctly.

Memo | If you try to save a new sequence program to an existing text file, the program will be added and saved at the end of that text file.

If you try to save a sequence program under an existing sequence program number within the same text file, the new sequence program will be added and saved at the end of the existing program.

However, if you download this text file to the controller, the first sequence program will be enabled and the latter sequence program will be deleted.

The leading sequence program is downloaded (the remaining sequence programs are deleted).

The same sequence program numbers are written.

```

Seq 2
[1] U1 2000
[2] D1 +5000
[3] INC1

Seq 2
[1] U1 100
[2] D1 +300
[3] INC1

Seq 2
[1] U2 500
[2] D2 +1000
[3] INC2

```

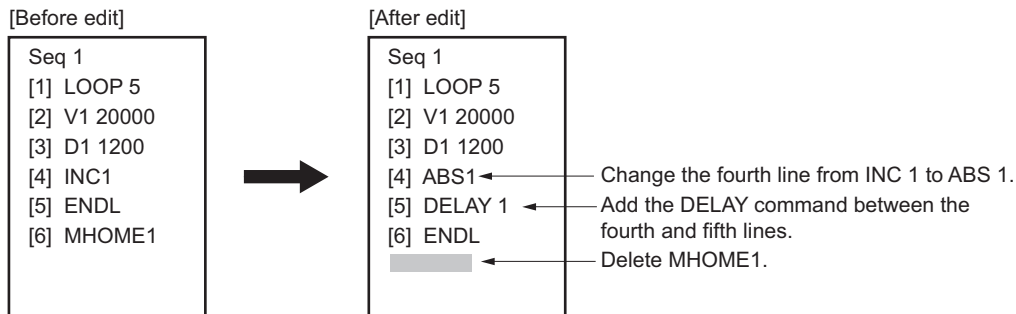

■ Example of editing a sequence program

The example below provides a step-by-step description of how sequence program 1 is edited under the following conditions:

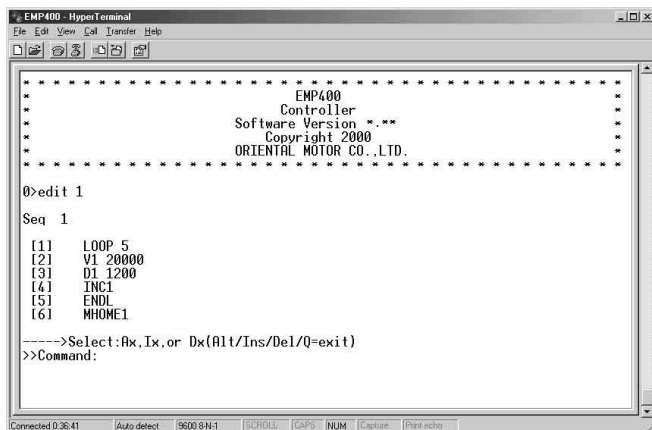

1. Type in “EDIT 1” and press the Enter key.

The contents of sequence program 1 is displayed for editing.



2. Follow the lines below to change the fourth line from “INC 1” to “ABS 1.”

- a. Type in “A4” and press the Enter key.

The fourth line is now ready for editing.

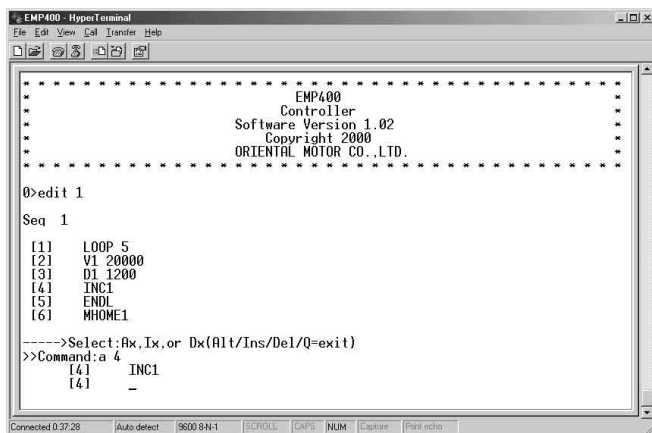

b. Type in “ABS 1.”

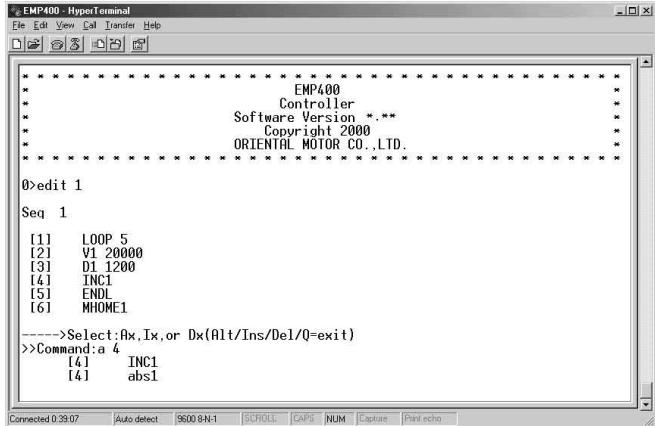

c. Press the Enter key.
The fourth line of sequence program 1 is changed to “ABS 1,” and you can now enter another command for editing.

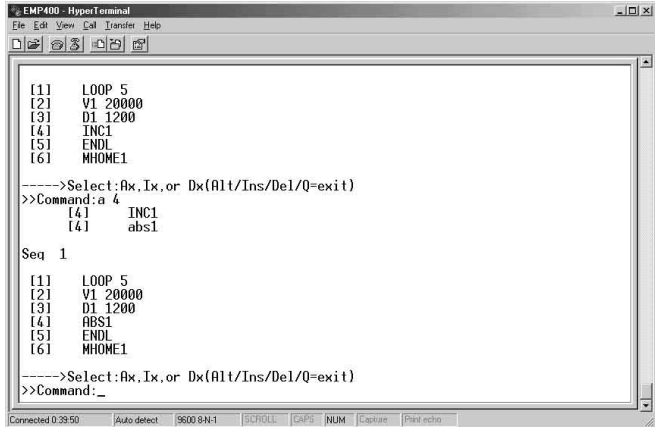

3. Follow the steps below to insert “DELAY 1” between the fourth and fifth lines.

- a. Type in “I 5” and press the Enter key.

The fifth line is added and now ready for command entry.

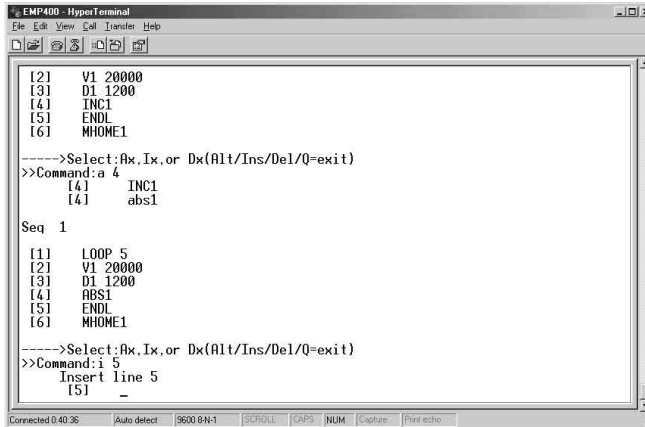

```
EMP400 - HyperTerminal
File Edit View Call Transfer Help
[2] V1 20000
[3] D1 1200
[4] INCL
[5] ENDL
[6] MHOME1

----->Select:Rx, Ix, or Dxx(Alt/Ins/Del/0=exit)
>>Command: a 4
      [4] INCL
      [4] abs1

Seq 1

[1] LOOP 5
[2] V1 20000
[3] D1 1200
[4] ABS1
[5] ENDL
[6] MHOME1

----->Select:Rx, Ix, or Dxx(Alt/Ins/Del/0=exit)
>>Command: i 5
      Insert line 5
      [5] -
```

- b. Type in “DELAY 1.”

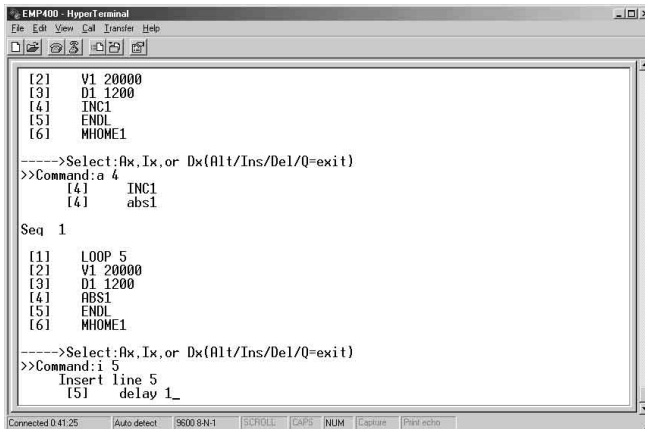

```
EMP400 - HyperTerminal
File Edit View Call Transfer Help
[2] V1 20000
[3] D1 1200
[4] INCL
[5] ENDL
[6] MHOME1

----->Select:Rx, Ix, or Dxx(Alt/Ins/Del/0=exit)
>>Command: a 4
      [4] INCL
      [4] abs1

Seq 1

[1] LOOP 5
[2] V1 20000
[3] D1 1200
[4] ABS1
[5] ENDL
[6] MHOME1

----->Select:Rx, Ix, or Dxx(Alt/Ins/Del/0=exit)
>>Command: i 5
      Insert line 5
      [5] delay 1_
```

c. Press the Enter key.

“DELAY 1” is added to the fifth line of sequence program 1, and the subsequent line number is changed. You can now enter another command for editing.

```

EMP400 - HyperTerminal
File Edit View Call Transfer Help
----->Select:fx,ix,or Dx(Alt/Ins/Del/Q=exit)
>>Command:i 5
      Insert line 5
      [5] delay 1

Seq 1
[1] LOOP 5
[2] V1 20000
[3] D1 1200
[4] ABS1
[5] DELAY 1
[6] ENDL
[7] MHOME1

----->Select:fx,ix,or Dx(Alt/Ins/Del/Q=exit)
>>Command:_

```

4. Follow the steps below to delete “MHOME 1” from the seventh line.

a. Type in “D 7” and press the Enter key.

A message appears, asking if you want to delete (Delete line 7 (Y/N)?).

```

EMP400 - HyperTerminal
File Edit View Call Transfer Help
----->Select:fx,ix,or Dx(Alt/Ins/Del/Q=exit)
>>Command:i 5
      Insert line 5
      [5] delay 1

Seq 1
[1] LOOP 5
[2] V1 20000
[3] D1 1200
[4] ABS1
[5] DELAY 1
[6] ENDL
[7] MHOME1

----->Select:fx,ix,or Dx(Alt/Ins/Del/Q=exit)
>>Command:d 7
      [7] MHOME1
      Delete line 7(Y/N)?

```

b. Type in “Y.”

```

EMP400 - HyperTerminal
File Edit View Call Transfer Help
[1] D1 1200
[4] ABS1
[5] ENDL
[6] MHOME1

----->Select:fx,ix,or Dx(Alt/Ins/Del/0=exit)
>>Command:i 5
      insert line 5
      [5] delay 1

Seq 1

[1] LOOP 5
[2] V1 20000
[3] D1 1200
[4] ABS1
[5] DELAY 1
[6] ENDL
[7] MHOME1

----->Select:fx,ix,or Dx(Alt/Ins/Del/0=exit)
>>Command:d 7
      [7] MHOME1
      Delete line 7(Y/N)?y_

Connected 0:43:25  Auto detect  9600 8N-1  SCROLL  CAPS  NUM  Capture  Print echo
    
```

c. Press the Enter key.

The seventh line of sequence program 1 is deleted, and you can now enter another command for editing.

```

EMP400 - HyperTerminal
File Edit View Call Transfer Help

[1] LOOP 5
[2] V1 20000
[3] D1 1200
[4] ABS1
[5] DELAY 1
[6] ENDL
[7] MHOME1

----->Select:fx,ix,or Dx(Alt/Ins/Del/0=exit)
>>Command:d 7
      [7] MHOME1
      Delete line 7(Y/N)?y

Seq 1

[1] LOOP 5
[2] V1 20000
[3] D1 1200
[4] ABS1
[5] DELAY 1
[6] ENDL

----->Select:fx,ix,or Dx(Alt/Ins/Del/0=exit)
>>Command:

Connected 0:44:06  Auto detect  9600 8N-1  SCROLL  CAPS  NUM  Capture  Print echo
    
```

Quitting the program editing

1. Type in the “Q” command to quit the program editing.

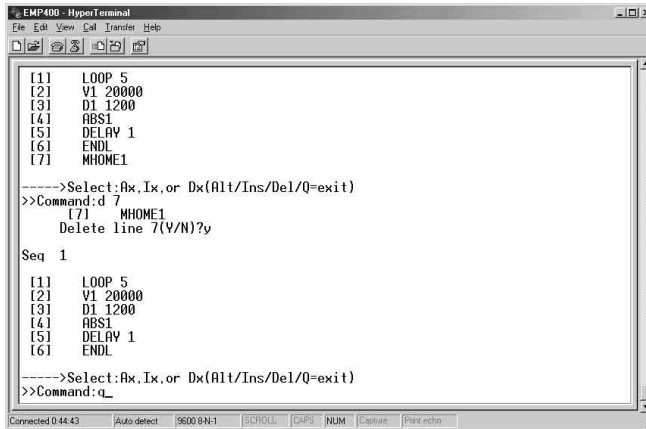

```

EMP400 - HyperTerminal
File Edit View Call Transfer Help
[Icons]

[1] LOOP 5
[2] V1 20000
[3] D1 1200
[4] ABS1
[5] DELAY 1
[6] ENDL
[7] MHOME1

----->Select:Rx,Ix, or Dx(Alt/Ins/Del/0=exit)
>>Command:d 7
      [7] MHOME1
      Delete line 7(Y/N)?y

Seq 1

[1] LOOP 5
[2] V1 20000
[3] D1 1200
[4] ABS1
[5] DELAY 1
[6] ENDL

----->Select:Rx,Ix, or Dx(Alt/Ins/Del/0=exit)
>>Command:q_
  
```

2. Press the Enter key.
This completes the program editing, and the “0>” command prompt is displayed.

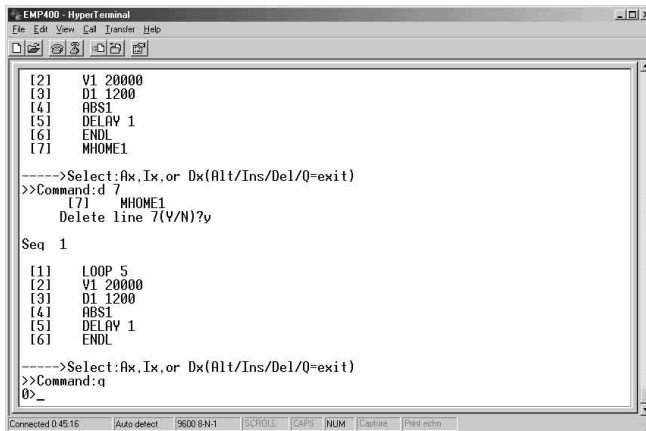

```

EMP400 - HyperTerminal
File Edit View Call Transfer Help
[Icons]

[2] V1 20000
[3] D1 1200
[4] ABS1
[5] DELAY 1
[6] ENDL
[7] MHOME1

----->Select:Rx,Ix, or Dx(Alt/Ins/Del/0=exit)
>>Command:d 7
      [7] MHOME1
      Delete line 7(Y/N)?y

Seq 1

[1] LOOP 5
[2] V1 20000
[3] D1 1200
[4] ABS1
[5] DELAY 1
[6] ENDL

----->Select:Rx,Ix, or Dx(Alt/Ins/Del/0=exit)
>>Command:q
0>_
  
```

7.6 List of messages associated with sequence program

The messages listed below may be displayed while writing, editing, downloading or uploading a sequence program.

An error message will appear if any invalid command or parameter is entered while editing a sequence program.

If an error message is displayed, go back to enter the A, I or D command again.

Message	Description
Can not Overwrite	You cannot overwrite an existing sequence program.
>> Command:	Enter a command.
Completed.	Downloading/uploading has been completed.
Delete line n (Y/N)?	The nth line will be deleted.
Empty...Direct Insert Mode. (ESC/Q = exit)	The sequence program is empty. A new program may be written.
End "TEXT CAPTURE"	Stop Text Capture of HyperTerminal.
Insert line n	The nth line will be inserted.
Invalid value.	An invalid parameter has been entered for the command you want to change or insert.
Line dose not exist.	The line you want to change/insert/delete does not exist.
Press ENTER key.	Press the Enter key.
Select: Ax, Ix, or Dx (Alt/Ins/Del/Q = exit)	Select the command for editing.
Select upload Sequence No. 0-31, 99, A (0-31, 99, ALL)?	Select the sequence program you want to upload.
Start DOWNLOAD	Start sending the text file via HyperTerminal.
Start "TEXT CAPTURE"	Start Text Capture of HyperTerminal.
Syntax error.	The command you want to change or insert is invalid.

8 Executing the sequence program

This section covers how to execute the sequence program you have written.

8.1 How to execute a sequence program

The sequence program saved in the controller memory may be executed in one of the following three methods:

■ Executing via the host controller

You can select and execute a sequence program via the host controller.

See section 8.2 “Program execution via the host controller” on p.48.

■ Automatic program execution

The sequence program you have written under sequence program number 99 is automatically executed upon power on or RESET command input.

See section 8.3 “Automatic program execution” on p.52.

■ Program execution via command

The sequence program may be executed by inputting an execution command to HyperTerminal.

See section 8.4 “Program execution via command” on p.52.

8.2 Program execution via the host controller

CN1, which is connected to the host controller connector, has M0 through M4 inputs for selecting the sequence program number and START input for execution of the sequence program.

You can select a sequence program number through a unique combination of M0 through M4 input conditions and execute the sequence program by activating the START input.

1. Use the host controller to select a sequence program you'd like to execute through a unique combination of M0 through M4 input conditions (CN1: 33 to 37 pins).

Sequence program No.	Input signal				
	M4	M3	M2	M1	M0
0	OFF	OFF	OFF	OFF	OFF
1	OFF	OFF	OFF	OFF	ON
2	OFF	OFF	OFF	ON	OFF
3	OFF	OFF	OFF	ON	ON
4	OFF	OFF	ON	OFF	OFF
5	OFF	OFF	ON	OFF	ON
6	OFF	OFF	ON	ON	OFF
7	OFF	OFF	ON	ON	ON
8	OFF	ON	OFF	OFF	OFF
9	OFF	ON	OFF	OFF	ON
10	OFF	ON	OFF	ON	OFF
11	OFF	ON	OFF	ON	ON
12	OFF	ON	ON	OFF	OFF
13	OFF	ON	ON	OFF	ON
14	OFF	ON	ON	ON	OFF
15	OFF	ON	ON	ON	ON

Sequence program No.	Input signal				
	M4	M3	M2	M1	M0
16	ON	OFF	OFF	OFF	OFF
17	ON	OFF	OFF	OFF	ON
18	ON	OFF	OFF	ON	OFF
19	ON	OFF	OFF	ON	ON
20	ON	OFF	ON	OFF	OFF
21	ON	OFF	ON	OFF	ON
22	ON	OFF	ON	ON	OFF
23	ON	OFF	ON	ON	ON
24	ON	ON	OFF	OFF	OFF
25	ON	ON	OFF	OFF	ON
26	ON	ON	OFF	ON	OFF
27	ON	ON	OFF	ON	ON
28	ON	ON	ON	OFF	OFF
29	ON	ON	ON	OFF	ON
30	ON	ON	ON	ON	OFF
31	ON	ON	ON	ON	ON

2. Turn the START input (CN1: 3 pins) to on via the host controller.
This will start the sequence program you have selected.

Example of sequence program execution

The timing chart below shows the status of operation with sequence program 1 when an S-STOP input is turned on during continuous operation as specified by sequence program 1 and sequence program 3 is executed subsequently.

Seq 1

[1] D 10000

[2] INC

[3] IN 1, 1

[4] H -

[5] SCAN

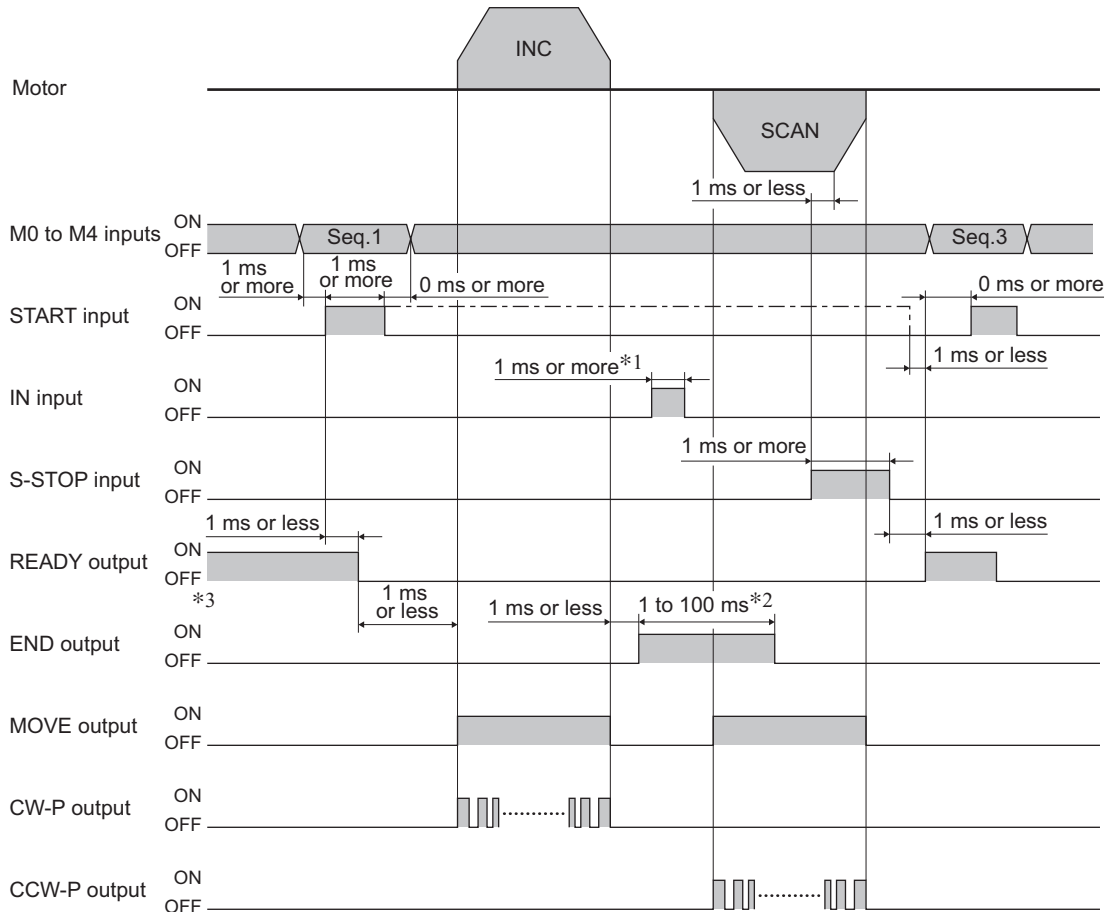

*1 To use a general-purpose input, set the duration of input's "ON" or "OFF" status to 1 ms or longer.

*2 The duration of END output can be set via the ETIME command. (The factory setting is 10 ms.)

*3 It will take approximately 3 seconds after the power is input until the READY output turns on.

External stop

The timing chart below shows the status of operation when an external stop signal (E-STOP input) is fed and the operation then resumes.

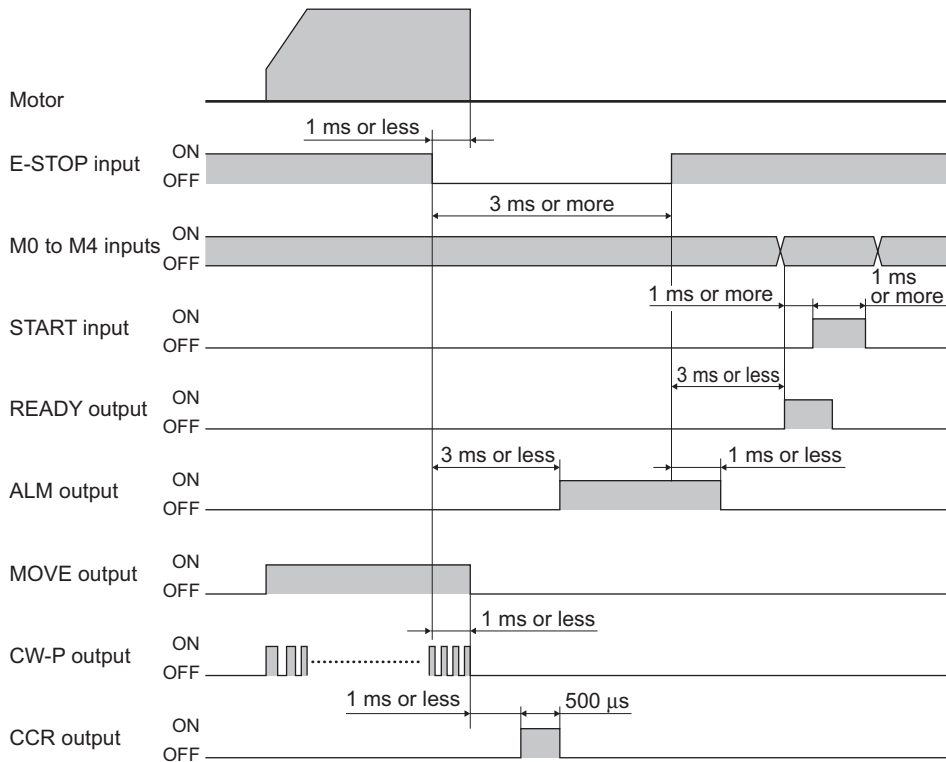

Alarm signal input from the driver

The timing chart below shows the status of operation when an alarm signal (ALM input) is fed from the driver during operation and the operation then resumes.

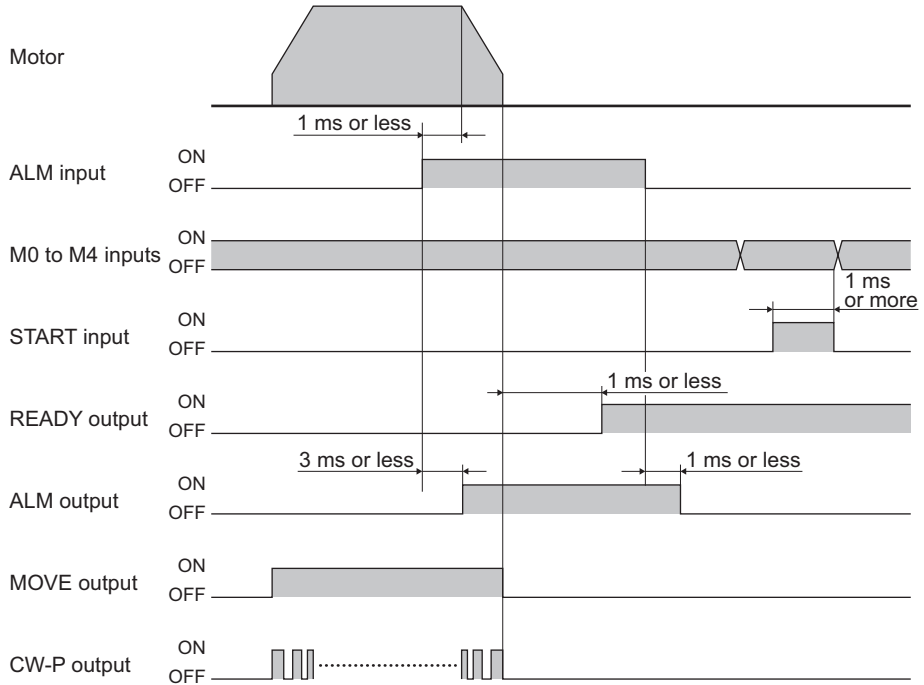

9 Program command

This section covers the keys and commands used for communication between the **EMP400** Series and HyperTerminal or another terminal program.

9.1 Command input

A sequence program consists of instructions to the controller (commands) and their parameters. Alphanumeric characters (case-insensitive) are used as input to a sequence program.

- Insert a space (or a comma) between a command and its parameter.

However, a space is not required between a command and its parameter, which specifies the axis. (An error message will be displayed if there is a space.)

Example: EDIT 1 (or EDIT, 1) ← Insert a space (or a comma) between the command (“EDIT”) and its parameter (“1”).

Example: RTNCR2 ← No space (or comma) between the command (“RTNCR”) and its parameter specifying the axis (“2”).

- When there are multiple parameters, insert a space (or a comma) between parameters, as well.

Example: IN 1 0 (or IN 1, 0) ← Insert a space (or a comma) between one parameter (“1”) and another parameter (“0”).

- For a command that requires you to specify an axis, after entering the command enter the axis to specify.

If no axis is entered, it is assumed that you have specified the first axis.

Example: To specify the first axis → PULSE1
To specify the second axis → EEN2

Note

Since **EMP401** has only one axis, there is no need to enter the parameter for axis specification.

Also, if you input “2” as the parameter for axis specification, an error will be generated.

- Some parameters can be omitted.

Of the parameters listed in section 9.5 “Command details” on p.62, parameters shown in parentheses can be omitted. However, parameters shown in brackets and parameters indicating the number of times (“n”) cannot be omitted.

Parameter type	Can be omitted	Description
(1 2)	Yes	Either 1 or 2 can be specified, but specifying neither will not generate an error. Also, if this parameter is omitted, it is assumed that “1” is specified.
[+ -]	No	Either a “+” or a “-” must be entered.
n	No	This is a parameter that specifies the number of times something is to be done. Enter a numeric value within the valid range.

- The number of sequence programs that can be created is 33, which is from sequence program numbers 0 through 31 and sequence program number 99.

A total of 1000 lines can be configured for 33 sequence programs.

Example: 125 lines × 8 sequence programs = 1000 lines

Example: 500 lines × 2 sequence programs = 1000 lines

- Command settings can be checked.

In the case of a command that can be input both directly and via a program, inputting the command directly will allow you to check the setting of the command that was last input.

Refer to the explanation under “Request” in each table provided in 9.5 “Command details” on p.62.

9.2 Command classification

Commands for the **EMP400** Series can be classified into the following categories:

- Hardware configuration commands
- Common commands
- Operation commands
- Other commands

Hardware configuration commands

Hardware configuration commands specify the settings for sensors and drivers.

Commands entered into sequence program 99 can automatically configure hardware when the power is turned on. A command setting is valid until changed by another command or the power is reset.

Command	Description	Default setting	Reference
ACTL	Switches the logical value of a sensor or an alarm.	±LS, HOME _{LS} , SLIT input: Normally open* ALM input, ALM output: Normally close	p.63
EEN	Sets the usage of END input.	Not used	p.67
ETIME	Sets the time for END output.	10 ms	p.69
ID	Initializes linear motion products (Configuration is performed when linear motion products are used.).	10,103,000,100,000	p.70
OFS	Sets the home offset.	0	p.76
PULSE	Sets the pulse output mode.	2-pulse mode	p.77
SEN	Sets the home detection mode.	3-sensor mode*	p.81
TIM	Sets the usage of TIM. input and SLIT input.	TIM. input: Not used SLIT input: Not used	p.82
UNIT	Sets the unit of movement.	Movement per pulse: 1* Division of step angle: 1.0*	p.83

* If the ID command is set, values from the ID command will be used.

Note | Once set, the ID command will remain stored even after the power is turned off.

Common commands

Common commands are commands that can be used for positioning operations, mechanical home seeking operation and continuous operations.

A command setting is valid until changed by another command or the power is reset.

Command	Description	Default setting	Reference
D	Sets the amount of movement or position data.	0	p.64
DOWEL	Sets the operation interval.	0	p.65
H	Sets the rotational direction.	+ (CW direction)	p.70
MU	Sets parallel processing.	0	p.75
RAMP	Sets the acceleration/deceleration pattern and jerk-limit time.	Acceleration/deceleration pattern: 0 (linear pattern) Jerk-limit time: 50 ms	p.78
T	Sets the acceleration/deceleration rate.	30.0 ms/kHz	p.82
V	Sets the operating speed.	10000 Hz*	p.85
VS	Sets the starting speed.	1000 Hz*	p.85

* If the ID command is set, values from the ID command will be used.

Operation commands

Operation commands deal with motor operation and other motor-related tasks.

Command	Description	Reference
ABS	Performs an absolute positioning operation.	p.62
INC	Performs an incremental positioning operation.	p.71
MHOME	Performs mechanical home seeking.	p.73
RESET	Resets software.	p.79
RTNCR	Sets the current position to 0 (clears the current position).	p.79
RUN	Executes a sequence program.	p.79
S	Decelerates the motor to a stop.	p.80
SCAN	Performs a continuous operation.	p.80

Below is a list of operations and functions for the **EMP400** Series:

Operation/function	Incremental operation	Absolute operation	Mechanical home seeking	Continuous operation
Linear acceleration/deceleration	○	○	○	○
Jerk-limit control	○	○	○	○
2-axis linear interpolation operation	○	○	–	–
Multistep speed-change operation	–	–	–	○
Escape from limit sensors ^{*1}	–	–	Mechanical home seeking	Operates at starting speed and stops after escape
When an alarm signal has been input from the driver	Decelerates to a stop	Decelerates to a stop	Decelerates to a stop	Decelerates to a stop
Operation from outside the manageable coordinates ^{*2}	○	–	○	○

*1 When the work triggers the limit sensor, an alarm is generated and the motor stops. For details, see section 11.1 “When the ALARM LED illuminates” on p.101.

*2 The controller is counting the number of pulses output. This count value has upper and lower limits, which constitute the manageable coordinates. For details, see the following page.

■ 2-axis linear interpolation operation

The 2-axis linear interpolation operation allows linear movement toward a target position by controlling 2 axes.

Since this operation applies to linear acceleration/deceleration mode, the operation will be performed in linear acceleration/deceleration mode even if the current setting is jerk-limit control.

In a 2-axis linear interpolation operation, the axis with larger movement set in the D command becomes the main axis, while the other becomes the sub-axis. The speed of the sub-axis is calculated from the main axis' speed and amount of movement.

Memo | If the amount of movement of the sub-axis is significantly smaller than that of the main axis, linear movement to the target position may not be achieved.

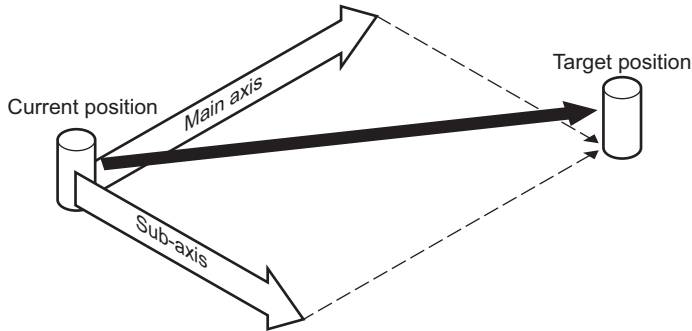

■ About manageable coordinates

During motor operation the controller keeps track of the number of pulses that have been output. The values of these counters are referred to as manageable coordinates. Manageable coordinates have upper and lower limits (manageable coordinate range). If the counter value lies outside the manageable coordinate range, the controller cannot count the number of pulses.

Incremental operation sets the movement amount based on the current position. Therefore, the motor can operate outside the manageable coordinate range.

On the other hand, absolute operation sets the movement amount from the reference point. Therefore, the motor does not operate if the movement violates the manageable coordinate range.

If the manageable coordinate range has been violated in absolute operation, see the section on “Position counter overflow. Please clear Position counter.” in section 11.2 “Error messages” on p.103, to reset the counter value for the number of pulses.

Incremental operation

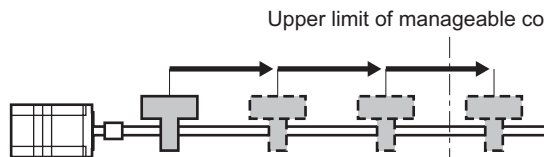

Incremental operation sets the movement amount based on the current position. Therefore, the motor operates outside the manageable coordinate range. However, pulses above the upper limit of manageable coordinates will not be counted.

Absolute operation

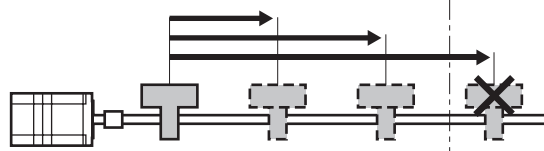

Absolute operation sets the movement amount from the reference point. Therefore, the motor does not operate if the movement violates the manageable coordinate range.

Other commands

■ Commands used in sequence programs

Command	Description	Reference
CJMP	Jumps to the specified step if the condition is met.	p.63
DELAY	Sets delay time.	p.65
ENDL	Ends a loop section.	p.68
JMP	Jumps to the specified step.	p.72
LOOP	Sets a loop section.	p.72

■ Commands used to edit sequence programs

Command	Description	Reference
DEL	Deletes a sequence program.	p.65
DWNLD	Downloads a sequence program.	p.66
EDIT	Edits a sequence program.	p.67
UPLD	Uploads a sequence program.	p.84

Note

Sequence programs are stored in the EEPROM.

The EEPROM allows 100,000 rewrites.

The EDIT command rewrites the EEPROM after editing a step.

The DWNLD command rewrites the EEPROM after downloading a file.

The DEL command rewrites the EEPROM after deleting a sequence program.

When considerable editing is to be done on a sequence program, to conserve the life of the EEPROM use the DWNLD command to download the sequence program instead of using the EDIT command.

■ Commands that control general-purpose I/O

Command	Description	Reference
IN	Checks general-purpose input. Waits for input.	p.71
OUT	Controls general-purpose output.	p.76

■ Request commands

Command	Description	Reference
R	Checks system status.	p.77

9.3 Special keys

Special keys that can be used during command input are described.

<BKSP>

Name	Backspace
Valid mode	Direct input
Function	Deletes one character from a command that has been input. Continuously using this key allows the deletion of the command until 0> (command prompt) is reached.
Example	–

<ENTER>

Name	Enter (execute, line-feed)
Valid mode	Direct input
Function	Starts the execution of the command that has been input. An error will be returned if there is an error in the command string. This special key can handle three patterns, which are <CR (0x0A)>, <LF + CR (0x0D + 0x0A)> and <CR + LF (0x0A + 0x0D)>.
Example	0>MHOME1<ENTER> → Executes mechanical home seeking

<ESC>

Name	Escape (discard input, decelerate to a stop, halt sequence program)
Valid mode	Direct input
Function	Discards the command that has been input, line-feeds and displays the next prompt. If this key is used during pulse output, the motor will decelerate to a stop according to the acceleration/deceleration rate from a T command. If this key is used during the execution of a sequence program, the sequence program will stop.
Example	0>MHOME<ESC> → Command line "MHOME" will be discarded and a new prompt will be displayed.

9.4 List of commands

Command	Description	Default setting	Reference
ABS	Performs an absolute positioning operation.		p.62
ACTL	Switches the logical value of a sensor or an alarm.	±LS: 0 (normally open) HOMELS: 0 (normally open) SLIT Sensor: 0 (normally open) Driver alarm input: 1 (normally closed) Alarm output: 1 (normally closed)	p.63
CJMP	Jumps to the specified step if the condition is met.		p.63
D	Sets the amount of movement or position data.	0	p.64
DEL	Deletes a sequence program.		p.65
DELAY	Sets delay time.		p.65
DOWEL	Sets the operation interval.	0	p.65
DWNLD	Downloads a sequence program.		p.66
EDIT	Edits a sequence program.		p.67
EEN	Sets the usage of END input.	0 (not used)	p.67
END	Ends a sequence program.		p.68
ENDL	Ends a loop section.		p.68
ETIME	Sets the time for END output.	10 ms	p.69
H	Sets the rotational direction.	+ (CW direction)	p.70
ID	Initializes linear motion products.	10,103,000,100,000	p.70
IN	Checks general-purpose input. Waits for input.		p.71
INC	Performs an incremental positioning operation.		p.71
JMP	Jumps to the specified step.		p.72
LOOP	Sets a loop section.		p.72
MHOME	Performs mechanical home seeking.		p.73
MU	Sets parallel processing.	0	p.75
OFS	Sets the home offset.	0	p.76
OUT	Controls general-purpose output		p.76
PULSE	Sets the pulse output mode.	2 (2-pulse mode)	p.77
R	Checks system status.		p.77
RAMP	Sets the acceleration/deceleration pattern and jerk-limit time.	Acceleration/deceleration pattern: 0 (linear pattern) Jerk-limit time: 50 ms	p.78
RESET	Resets software.		p.79
RTNCR	Sets the current position to 0 (clears the current position).		p.79
RUN	Execute a sequence program.		p.79
S	Decelerates the motor to a stop.		p.80

Command	Description	Default setting	Reference
SCAN	Performs a continuous operation.		p.80
SEN	Sets the home detection mode.	3 (3-sensor mode)	p.81
T	Sets the acceleration/deceleration rate.	30 ms/kHz	p.82
TIM	Sets the usage of TIM. input and SLIT input.	TIM. input: 0 (not used) SLIT input: 0 (not used)	p.82
UNIT	Sets the unit of movement.	Unit: 1 Division of step angle: 1.0	p.83
UPLD	Uploads a sequence program.		p.84
V	Sets the operating speed.	10000 Hz	p.85
VS	Sets the starting speed.	1000 Hz	p.85

9.5 Command details

For the command input method, refer to 9.1 “Command input” on p.53.

ABS

Name	Absolute positioning operation		
Valid mode	Direct input/program		
Syntax	ABS (1 2 C)		
	Parameter		Data range
	(1 2 C)	Axis	1 (operate axis 1), 2 (operate axis 2), C (perform a 2-axis linear interpolation operation, operating both axes simultaneously) If this parameter is omitted, axis 1 will be selected.
Function	<p>Performs an absolute operation until the current position matches the specified position data.</p> <p>Movement amount, starting speed, operating speed and acceleration/deceleration rate are to be set prior to this command.</p> <p>Operation can be ended by an S command, <ESC> key, or by an external S-STOP input.</p> <p>In a 2-axis linear interpolation operation, the axis whose movement amount set by a D command is greater becomes the main axis, while the other axis becomes the sub-axis. The speed of the sub-axis is calculated from the speed and movement amount of the main axis.</p> <p>When this command is set in a sequence program, the next line will be executed after the operation ends.</p> <p>If the END input is enabled by an EEN command, the next step will be executed when the END input turns on after the operation has ended.</p>		
Request	-		

■ Absolute operation

Absolute operation sets the relative position from the point of reference.

This method is suitable when moving directly to a specified position from any given position or when the positioning point changes frequently.

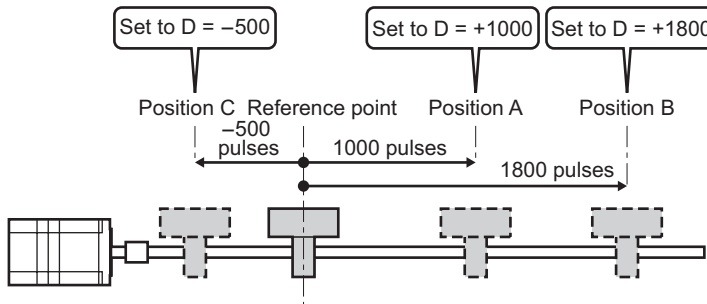

ACTL

Name	Switch I/O logical value			
Valid mode	Direct input/program			
Syntax	ACTL (1 2) [, □] n1 [, □] n2 [, □] n3 [, □] n4 ([, □] n5)			
		Parameter	Data range	Default
	(1 2)	Axis	1 (operate axis 1), 2 (operate axis 2) If this parameter is omitted, axis 1 will be operated.	
	n1	±LS logic	0 (normally open), 1 (normally close)	0
	n2	HOMELS logic	0 (normally open), 1 (normally close)	0
	n3	SLIT sensor logic	0 (normally open), 1 (normally close)	0
	n4	Driver alarm input logic	0 (normally open), 1 (normally close)	1
n5	Alarm output logic	0 (normally open), 1 (normally close)	1	
Function	Switches the logical value of a sensor or an alarm. Set the I/O values depending on the user's system configuration.			
Request	0>ACTL1 0: ACTL1 0, 0, 0, 1, 1 0>ACTL2 0: ACTL2 0, 1, 0, 1, 1			

CJMP

Name	Conditional jump			
Valid mode	-/Program			
Syntax	CJMP [, □] n1 [, □] n2 [, □] n3			
		Parameter	Data range	Default
	n1	General-purpose input number specified	1 to 8	
	n2	Logical value	0 (off), 1 (on)	
n3	Jump destination line number	Line 1 to 1000. (Only for line numbers used in the sequence program.)		
Function	A conditional jump will be executed, depending on the status of a general-purpose input. If n1 (general-purpose input number specified) matches n2 (logical value), the program jumps to n3 (jump destination step number). If they do not match, the program will move to the next line. If the specified line number is not found in the sequence program, the sequence program will stop.			
Request	-			

* For a sample sequence program using the CJMP command, see section 12.5 "Conditional jump procedure" on p.113.

D

Name	Set movement amount or position data			
Valid mode	Direct input/program			
Syntax	D (1 2) [, □] (+ -) n			
	Parameter		Data range	Default
	(1 2)	Axis	1 (select axis 1), 2 (select axis 2) If this parameter is omitted, axis 1 will be selected.	
	(+ -)*	Direction	+ (CW direction), - (CCW direction) If this parameter is omitted, the rotational direction in the H command will be used.	
	n	Movement amount or position data	Up to eight digits can be entered. Entered data will be internally converted to number of pulses. If the calculated number of pulses falls outside the range below, an error message will be displayed when a positioning operation is executed. Incremental operation: ±16,777,215 pulses Absolute operation: -8,388,608 to +8,388,607 pulses	0
Function	<p>Movement amount is set for incremental operation, while position data is set for absolute operation.</p> <p>If the direction is set by "+" or "-", the direction for the H command changes as well. This setting can be performed during an operation. However, the new settings will take effect starting from the next operation.</p>			
Request	<p>0>D 0: D1 = +1000 0>D1 0: D1 = +1000 0>D2 0: D2 = -1000</p>			

Note * : When setting position data for absolute operation, be sure to input a direction parameter. If a direction parameter is omitted, the direction of the last H command will be used.

Memo Converting D command data into number of pulses when unit value has been set:
Pulse number = (D command data/Movement per pulse) × Division of step angle
If this calculation yields a pulse number with fractions, the fractional portion will be discarded.
Example: If the calculation resulted in 10.5 pulses, use 10 pulses. If the calculation resulted in -10.5 pulses, then use -10 pulses.

DEL

Name	Delete sequence program			
Valid mode	Direct input			
Syntax	DEL [, □] n			
	Parameter		Data range	Default
	n	Sequence program number	0 to 31 or 99 (sequence program number) A (all sequence programs)	
Function	Deletes a sequence program. If the parameter is set to "A," all sequence programs will be deleted. Before deleting, a confirmation message ">Delete Seq. (n): (Y/N)?" will be displayed. Enter "Y" to delete the sequence program.			
Request	-			

DELAY

Name	Set delay time			
Valid mode	-/Program			
Syntax	DELAY [, □] n			
	Parameter		Data range	Default
	n	Delay time	0.01 to 99.99 seconds Two digits after the decimal point are valid. To set a fractional value, enter the integral part first, for instance as "0.12."	
Function	Once the set time has elapsed, the program moves to the next command.			
Request	-			

DOWEL

Name	Set operation interval			
Valid mode	Direct input/program			
Syntax	DOWEL (1 2) [, □] n			
	Parameter		Data range	Default
	(1 2)	Axis	1 (select axis 1), 2 (select axis 2) If this parameter is omitted, axis 1 will be selected.	
	n	Operation interval	0 to 100 ms	0
Function	When performing operations in succession, following the completion of an operation the system waits for specified time before starting the next operation. This command is effective for positioning operations, continuous operations and mechanical home seeking.			
Request	0>DOWEL2 0: DOWEL2 = 10			

■ Example using the DOWEL command

Sample sequence program:

- [1] D1000
- [2] DOWEL 10
- [3] INC
- [4] INC

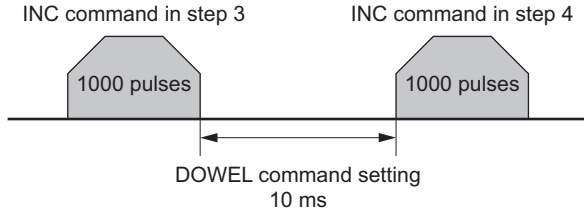

DWNLD

Name	Download		
Valid mode	Direct input		
Syntax	DWNLD		
	Parameter	Data range	Default
	-		
Function	Downloads a sequence program created by a text editor (or file) to the controller. Only text data can be downloaded.		
Request	-		

EDIT

Name	Edit sequence program		
Valid mode	Direct input		
Syntax	EDIT [, □] n		
	Parameter		Data range
	n	Sequence program number	0 to 31, 99
Function	A sequence program can be edited from the line editor. If the sequence program number is not entered, a list of sequence program numbers and the line numbers will be displayed. The number of remaining lines will be displayed in a message.		
Request	0>EDIT SEQUENCE DIRECTORY: Seq.0 0Steps. Seq.1 0Steps. Seq.2 0Steps. Seq.3 0Steps. Seq.4 0Steps. Seq.5 0Steps. Seq.6 0Steps. Seq.7 0Steps. Seq.8 0Steps. Seq.9 0Steps. Seq.10 0Steps. Seq.11 0Steps. Seq.12 0Steps. Seq.13 0Steps. Seq.14 0Steps. Seq.15 0Steps. Seq.16 0Steps. Seq.17 0Steps. Seq.18 0Steps. Seq.19 0Steps. Seq.20 0Steps. Seq.21 0Steps. Seq.22 0Steps. Seq.23 0Steps. Seq.24 0Steps. Seq.25 0Steps. Seq.26 0Steps. Seq.27 0Steps. Seq.28 0Steps. Seq.29 0Steps. Seq.30 0Steps. Seq.31 0Steps. Config* 0Steps. *1000Steps free.		

* Config refers to sequence program 99.

EEN

Name	Set END input		
Valid mode	Direct input/program		
Syntax	EEN (1 2) [, □] n		
	Parameter		Data range
	(1 2)	Axis	1 (select axis 1), 2 (select axis 2) If this parameter is omitted, axis 1 will be selected.
n	Validity of END input	0 (invalid), 1 (valid)	0
Function	After the motor operation ends, validates or invalidates the END input from a servo motor or the <i>αSTEP</i> driver. Always set this to "valid" when using a servo motor or <i>αSTEP</i> . When this is set to "valid," if END input does not turn on within one second after the end of pulse output from the controller, ALM output will turn on and the sequence program will end.		
Request	0>EEN1 0: EEN = 1 0>EEN2 0: EEN2 = 1		

END

Name	End sequence program		
Valid mode	-/Program		
Syntax	END		
	Parameter	Data range	Default
	-		
Function	Ends a sequence program. When this command is executed during continuous operation, the motor will decelerate to a stop.		
Request	-		

ENDL

Name	End loop section		
Valid mode	-/Program		
Syntax	ENDL		
	Parameter	Data range	Default
	-		
Function	Indicates the end of a loop section.		
Request	-		

ETIME

Name	Set END output time		
Valid mode	Direct input/program		
Syntax	ETIME [, □] n		
	Parameter		Default
	n	END output time	1 to 100 ms 10
Function	Sets the time for END output that is output after the completion of an incremental or absolute positioning operation.		
Request	0>ETIME 0: ETIME = 10		

■ About END output time

The amount of time set by the ETIME command is shown in the diagram.

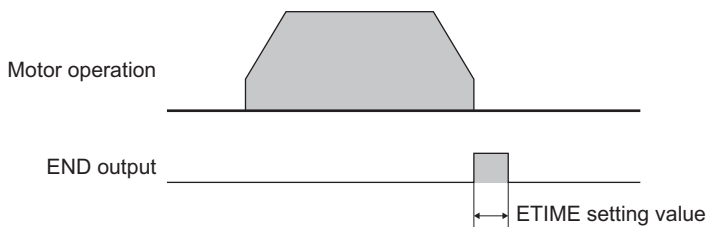

If the next positioning operation ends while the END output is on, the END output will turn on for the amount of time set by the ETIME command following completion of the last positioning operation.

Example:

- [1] ETIME 100 Sets the END output time to 100 ms
- [2] D1 1 Sets the movement amount for the first axis to 1-pulse
- [3] D2 1 Sets the movement amount for the second axis to 1-pulse
- [4] INC1 Positioning operation for the first axis
- [5] INC2 Positioning operation for the second axis

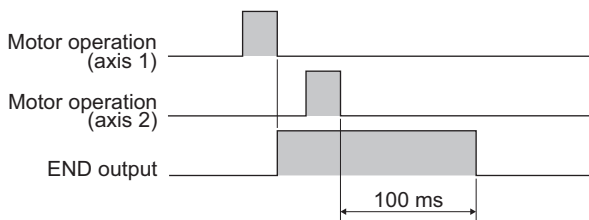

H

Name	Set rotational direction			
Valid mode	Direct input/program			
Syntax	H (1 2) [, □] [+ -]			
	Parameter		Data range	Default
	(1 2)	Axis	1 (select axis 1), 2 (select axis 2) If this parameter is omitted, axis 1 will be selected.	
	[+ -]	Rotational direction	+ (CW direction), - (CCW direction)	+
Function	Sets the direction of movement for positioning and continuous operation. Also sets the direction in which home position detection starts during mechanical home seeking.			
Request	0>H1 0: H1 = +			

ID

Name	Set ID			
Valid mode	Direct input/program			
Syntax	ID (1 2) [, □] n			
	Parameter		Data range	Default
	(1 2)	Axis	1 (select axis 1), 2 (select axis 2) If this parameter is omitted, axis 1 will be selected.	
	n	ID	14 digits	10,103,000,100,000
Function	By entering the ID of the linear motion product, initialization of the controller corresponding to the linear motion product will be performed. The parameters that will be initialized are VS, V, SEN, OFS, ACTL and UNIT. To reset the values to the factory default setting, enter the initial values. When the ID is set, the current position data is cleared.			
Request	0>ID1 0: ID1 = 10103000100000			

Note

The ID setting is stored in the EEPROM. Since there is a limit to how many times the EEPROM can be rewritten, do not write an ID command in a sequence program. If an ID command is written in a sequence program, the command will be written to the EEPROM each time the program is executed.

IN

Name	Confirm general-purpose input, waits for input		
Valid mode	Direct input (request only)/program		
Syntax	This command can be one of the following two types: 1. IN [, □] n1 [, □] n2 (waits until the specified general-purpose input changes to the specified logical status) 2. IN [, □] n3 (waits until all general-purpose input changes to the specified logical status)		
	Parameter		Data range
	n1	Specified general-purpose input number1	1 to 8
	n2	Logical value	0 (OFF), 1 (ON)
n3	Logical status of all general -purpose inputs	00,000,000 to 11,111,111	
Function	Input status is displayed when used as a request. When used inside a sequence program, the control waits until the input changes to the specified logical status. To wait until all general-purpose input statuses match, state the condition in the order of IN 8, 7, 6, 5, 4, 3, 2, 1. Input status will be displayed in this order when used as a request.		
Request	0>IN 0: IN 00101100		

Memo | For a sample sequence program using the IN command, see section 12.1 “Operation by the host controller” on p.108 or section 12.2 “Speed change operation by the host controller” on p.108.

INC

Name	Incremental positioning operation		
Valid mode	Direct input/program		
Syntax	INC (1 2 C)		
	Parameter		Data range
	(1 2 C)	Axis	1 (operate axis 1), 2 (operate axis 2), C (perform a 2-axis linear interpolation operation, operating both axes simultaneously) If this parameter is omitted, axis 1 will be operated.
Function	Performs an incremental operation until the current position matches the specified position data. Movement amount, starting speed, operating speed and acceleration/deceleration rate are to be set prior to this command. Operation can be ended by an S command, <ESC> key, or by an external S-STOP input. In a 2-axis linear interpolation operation, the axis whose movement amount set by a D command is greater becomes the main axis, while the other axis becomes the sub-axis. The speed of the sub-axis is calculated from the speed and movement amount of the main axis. When this command is set in a sequence program, the next line will be executed after the operation ends. If the END input is enabled by an EEN command, the next step will be executed when the END input turns on after the operation has ended.		
Request	-		

■ Incremental operation

Incremental operation sets the amount of movement based on the current position.

This method is suitable when the amount of movement is known ahead of time or when the same amount of movement is used repeatedly.

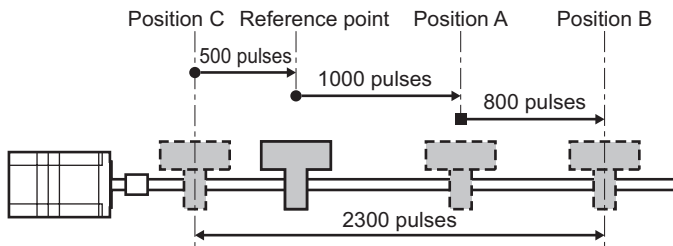

JMP

Name	Jump to a specified step		
Valid mode	-/Program		
Syntax	JMP [, □] n		
	Parameter		Data range
	n	Jump destination line number	Line 1 to line 1000. (Only for line numbers used in the sequence program.)
Function	Jumps to the specified line number. If the specified line number is not found in the sequence program, the sequence program will stop.		
Request	-		

LOOP

Name	Set a loop		
Valid mode	-/Program		
Syntax	LOOP [, □] n		
	Parameter		Data range
	n	Number of iterations	1 to 99
Function	Program iterates for the specified number of times between this command and the ENDL command. If the program control had been transferred into the LOOP to ENDL section from outside the loop by means of a JMP command or a CJMP command, the loop will not be iterated and stop. If the control is transferred from within the loop to the outside, the nesting level will be cleared. Loops can be nested up to four times.		
Request	-		

Note For each LOOP command, always set one ENDL command.

MHOME

Name	Mechanical home seeking			
Valid mode	Direct input/program			
Syntax	MHOME (1 2)			
		Parameter	Data range	Default
	(1 2)	Axis	1 (operate axis 1), 2 (operate axis 2) If this parameter is omitted, axis 1 will be operated.	
Function	<p>Executes mechanical home seeking.</p> <p>The starting speed, operating speed and acceleration/deceleration rate are to be set prior to this command.</p> <p>Other settings that must be performed in advance are TIM. input and SLIT input by a TIM command, initial home detection direction by an H command, home detection mode by an SEN command, and the offset movement amount by an OFS command.</p> <p>If the END input is enabled by an EEN command, the next step will be executed when the END input turns on after the operation has ended.</p>			
Request	-			

■ About mechanical home seeking

Mechanical home seeking is an operation that automatically detects the sensor located at the reference point for positioning operations (i.e., mechanical home position).

Home detection can be done either by a 2-sensor mode (constant-speed operation) or a 3-sensor mode (high-speed operation).

The initial direction of home detection will be determined by the rotational direction.

Operation differs, depending on the initial direction of home detection and the current position for both 2-sensor and 3-sensor modes. In the 2-sensor mode, rectangular operation will be performed at the starting speed.

Home position can be detected with higher precision when timing signals and slit signals are used.

When a home offset is set, the speed of mechanical home seeking will conform to the operating speed.

• Example of operation sequence in 2-sensor mode

----- indicates when home-offset travel has been set.

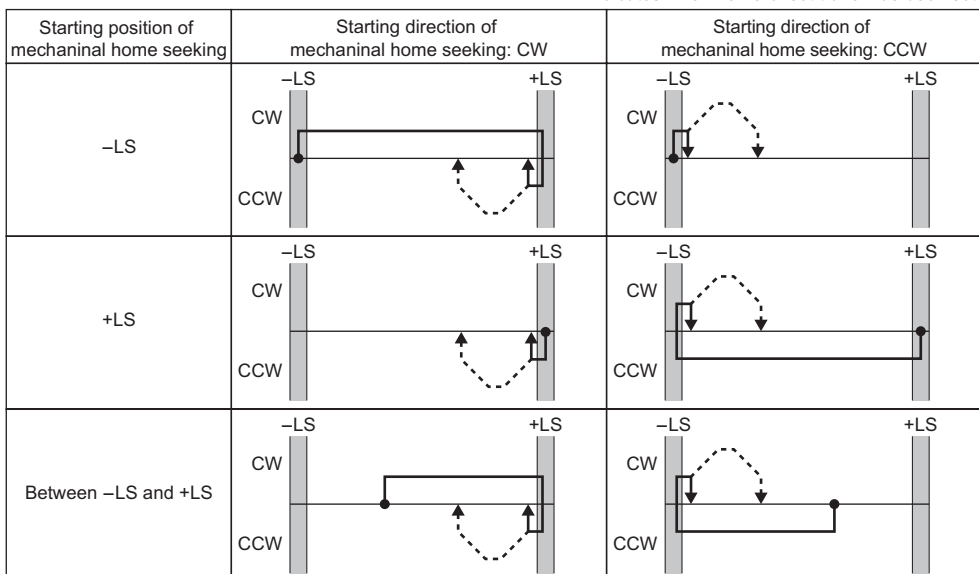

- Example of operation sequence in 3-sensor mode

----- indicates when home-offset travel has been set.

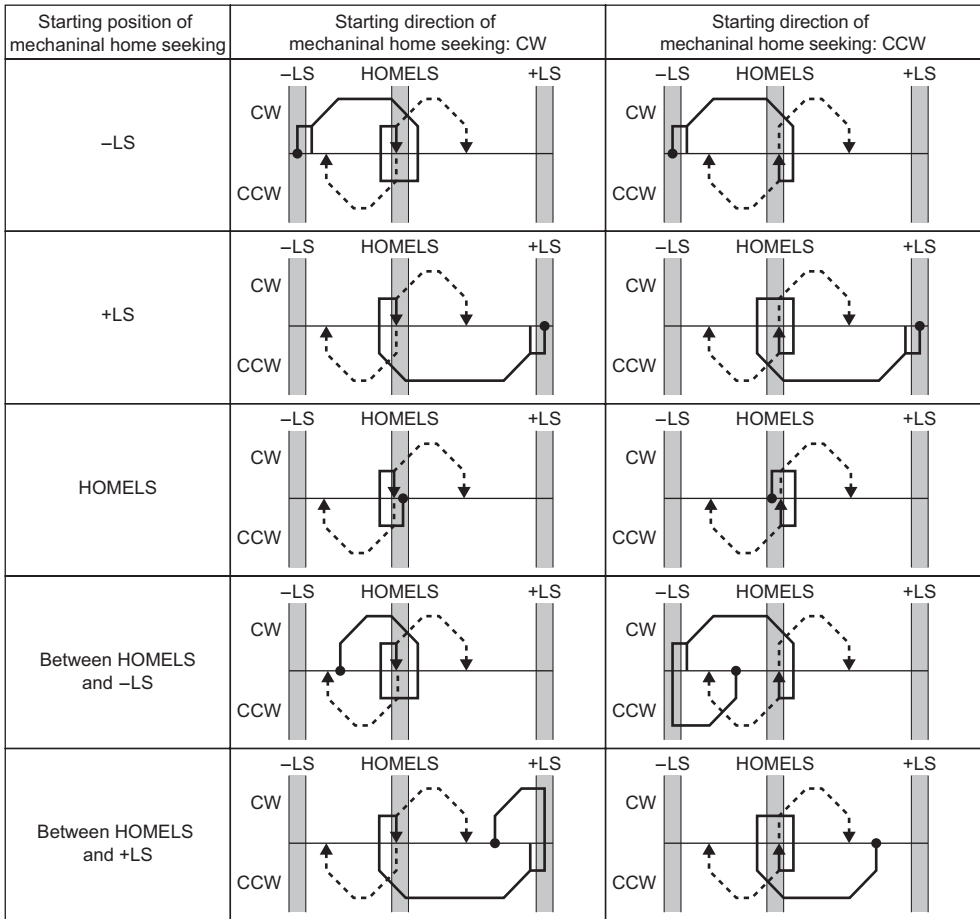

MU

Name	Set parallel processing			
Valid mode	Direct input/program			
Syntax	MU [, □] n			
		Parameter	Data range	Default
	n	Enable/disable parallel processing	0 (disable parallel processing), 1 (enable parallel processing)	0
Function	Sets parallel processing. If parallel processing is “disabled,” the next line will be executed after pulse output ends. If parallel processing is “enabled,” the next line will be executed when pulse output starts.			
Request	0>MU 0: MU = 0			

■ Example of parallel processing

When disabling parallel processing

During the execution of a positioning operation or mechanical home seeking, the next line will not be executed until pulse output ends.*

Example:

- [1] MU0 Disables parallel processing
- [2] INC1 Positioning operation for the first axis
- [3] DELAY1 Stands by for one second
- [4] INC2 Positioning operation for the second axis
- [5] OUT1, 1 Turns on general-purpose output 1

* Excludes continuous operation

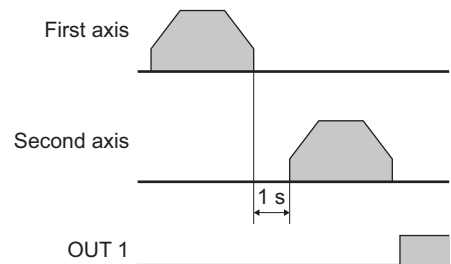

When enabling parallel processing

The next line is executed when pulse output begins. An axis can be controlled regardless of the status of the other axis. It is also possible to control general-purpose I/O during motor operation.

Example:

- [1] MU1 Enables parallel processing
- [2] INC1 Positioning operation for the first axis
- [3] DELAY1 Stands by for one second
- [4] INC2 Positioning operation for the second axis
- [5] OUT1, 1 Turns on general-purpose output 1

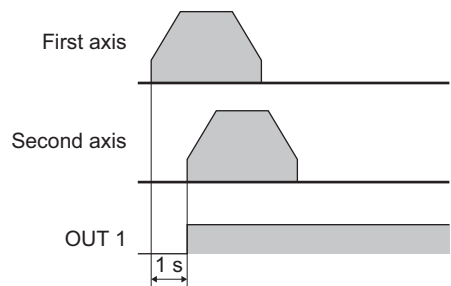

Note This command is used to perform parallel processing involving 2 axes. Commanding parallel processing on a single axis may result in position offset.

OFS

Name	Set home-position offset		
Valid mode	Direct input/program		
Syntax	OFS (1 2) [, □] (+ -) n		
	Parameter		Default
	(1 2)	Axis	1 (select axis 1), 2 (select axis 2) If this parameter is omitted, axis 1 will be selected.
	(+ -)	Rotational direction	+ (CW direction), - (CCW direction) If this parameter is omitted, the CW direction will be specified.
n	Movement amount or position data	Up to eight digits can be entered, excluding the decimal point. Entered data will be internally converted to number of pulses. If the calculated number of pulses falls outside the range below, an error message will be displayed when mechanical home seeking is executed. Pulse range: ±16,777,215 pulses	0
Function	Sets the offset from the home position used in mechanical home seeking		
Request	0>OFS 0: OFS1 = 10 0>OFS1 0: OFS1 = 10 0>OFS2 0: OFS2 = 20		

OUT

Name	Control general-purpose output		
Valid mode	Direct input/program		
Syntax	This command can be one of the following two types: 1. OUT [, □] n1 [, □] n2 (sets the specified general-purpose output) 2. OUT [, □] n3 (sets all general-purpose outputs)		
	Parameter		Default
	n1	Specified general-purpose output number	1 to 6
	n2	Logical value	0 (OFF), 1 (ON)
	n3	Logical status of all general-purpose outputs	000,000 to 111,111
Function	Controls general-purpose output. Set the values to either 0 (off) or 1 (on) in the order of OUT 6, 5, 4, 3, 2, 1.		
Request	0>OUT 0: OUT 000000		

PULSE

Name	Set the pulse output mode		
Valid mode	Direct input/program		
Syntax	PULSE (1 2) [,] n		
	Parameter		Data range
	(1 2)	Axis	1 (select axis 1), 2 (select axis 2) If this parameter is omitted, axis 1 will be selected.
n	Setting for pulse output mode	1 (1-pulse mode), 2 (2-pulse mode)	2
Function	Sets the pulse output mode. Set the mode to either 1-pulse mode (PULSE/DIR.) or 2-pulse mode (CW/CCW).		
Request	0>PULSE1 0: PULSE1 = 1 0>PULSE2 0: PULSE2 = 2		

R

Name	System request		
Valid mode	Direct input		
Syntax	R (1 2)		
	Parameter		Data range
	(1 2)	Axis	1 (select axis 1), 2 (select axis 2) If this parameter is omitted, axis 1 will be selected.
Function	Displays the I/O status, system information and parameter settings for the specified axis. Product name: Name of the product, name of the product for axis 1, name of the product for axis 2 System status: Operating status Error: The last error message displayed Hardware status: I/O status of the hardware Motion parameters: Present parameter settings Position: Current position		
Request	0>R		

```

EMP402 - HyperTerminal
File Edit View Call Transfer Help
0>r
EMP402
System status:
Idle Seq 0 -Step 1
Error:
-----
Hardware status:
Start = 0 E-stop = 0 S-stop = 0 M4-M0 = 00000
Ready = 0 Move = 0 End(OUT) = 0 Alarm = 0
IN = 10101111
CWL1 = 0 CCHL1 = 0 Home1 = 0
Tim1 = 0 Slit1 = 0 End(IN)1 = 1 DriverAlarm1 = 0
Motion parameters:
ETIME = 10 MU = 0
TDI = 10103000100000
RC11 = 0.0,0,1,1
PULSE1 = 2 EEN1 = 0 UNIT1 = 1,1
SEN1 = 3 TIM1 = 0.0 OFS1 = 0
VSL = 1000 V1 = 10000 T1 = 30
HI = * D1 = 0
DOWEL1 = 0 RAMP1 = 0,50
Position:
PCL = 0
0>_
Connected 0.00.23 Auto detect 9600 8N-1 [SERIAL] [GAPS] [NUM] [Capture] [Print echo]

```

RAMP

Name	Set acceleration/deceleration pattern and jerk-limit time		
Valid mode	Direct input/program		
Syntax	RAMP (1 2) [, □] n1 ([, □] n2)		
	Parameter		Data range
	(1 2)	Axis	1 (select axis 1), 2 (select axis 2) If this parameter is omitted, axis 1 will be selected.
	n1	Acceleration/deceleration mode	0 (linear acceleration/deceleration) 1 (jerk-limit control)
	n2	Jerk-limit time	0.1 to 200,000.0 (0.1 ms increments) If this parameter is omitted, initial value will be used.
Function	Sets the acceleration/deceleration pattern. For the acceleration/deceleration pattern, select either linear acceleration/deceleration or jerk-limit control. The acceleration/deceleration pattern set here is common to positioning, continuous and mechanical home seeking operations (excluding the 2-axis linear interpolation operation). Jerk-limit time will be valid when the acceleration/deceleration pattern is set to jerk-limit control. This setting will be invalid under the linear acceleration/deceleration setting.		
Request	0>RAMP1 0: RAMP1 = 0, 50 0>RAMP2 0: RAMP2 = 0, 50		

■ About jerk-limit time

Set the jerk-limit time when the acceleration/deceleration pattern is set to jerk-limit control mode. Jerk-limit time n2 applies to the sections shown in the diagram below.

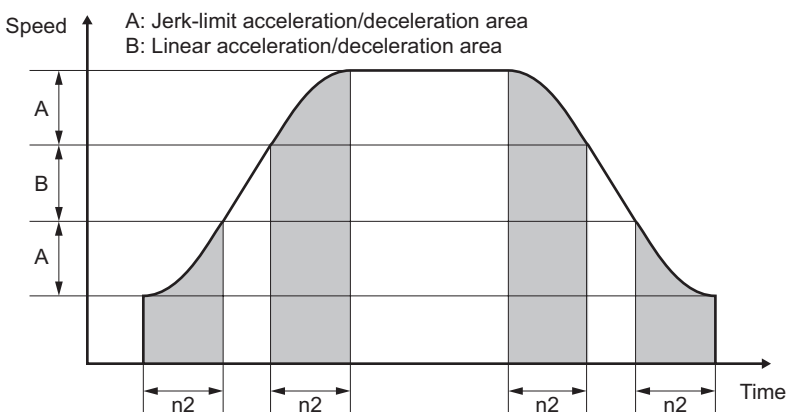

Memo | If a value corresponding to twice the jerk-limit time exceeds the acceleration/deceleration time, the jerk-limit time n2 will be adjusted to one half the acceleration/deceleration time. The linear acceleration/deceleration area will disappear.

RESET

Name	Reset software		
Valid mode	Direct input		
Syntax	RESET		
	Parameter		Data range
	-		Default
Function	Resets the software. After the reset, the software will enter the same condition it normally would after the power has been turned on, and the parameters associated with hardware configuration commands and common commands will be initialized (excluding ID command). The general-purpose outputs will turn off. After a reset, sequence program 99 (CONFIG program) is run.		
Request	-		

Note Executing a RESET command during operation will immediately stop the operation. Execute a RESET command after ending the operation by executing a S command, pressing the <ESC> key or turning on a S-STOP input externally.

RTNCR

Name	Clear current position		
Valid mode	Direct input/program		
Syntax	RTNCR (1 2)		
	Parameter		Data range
	(1 2)	Axis	1 (select axis 1), 2 (select axis 2) If this parameter is omitted, axis 1 will be selected.
Function	Clears the current position (sets it to 0).		
Request	-		

RUN

Name	Run a sequence program		
Valid mode	Direct input		
Syntax	RUN [, □] n		
	Parameter		Data range
	n	Sequence program number	0 to 31, 99
Function	Runs the specified sequence program. This command is invalid when a sequence program is running or when a pulse is being output.		
Request	-		

S

Name	Decelerate to a stop			
Valid mode	Direct input/program			
Syntax	S (1 2)			
		Parameter	Data range	Default
	(1 2)	Axis	1 (select axis 1), 2 (select axis 2) If this parameter is omitted, axis 1 will be selected.	
Function	If this command is input during pulse output, the motor will decelerate to a stop according to the acceleration/deceleration rate set in the T command.			
Request	-			

Note To stop a sequence program or 2-axis linear interpolation operation, press the <ESC> key or turn on a S-STOP input externally.

SCAN

Name	Continuous operation			
Valid mode	Direct input/program			
Syntax	SCAN (1 2)			
		Parameter	Data range	Default
	(1 2)	Axis	1 (operate axis 1), 2 (operate axis 2) If this parameter is omitted, axis 1 will be operated.	
Function	<p>Performs a continuous operation.</p> <p>The starting speed, operating speed, acceleration/deceleration rate and rotational direction are to be set prior to this command.</p> <p>Operation can be ended by an S command, <ESC> key, or by an external S-STOP input.</p> <p>A multistep speed-change operation can be performed if the operating speed is changed during an operation.</p> <p>When this command is set in a sequence program, the next line will be executed after the operation ends.</p>			
Request	-			

About continuous operation

A continuous operation keeps emitting pulses repeatedly until a command that stops the operation is executed. If the operating speed (V) is changed during a continuous operation, multistep speed-change operation can be performed. The starting speed (VS), acceleration/deceleration rate (T) and rotational direction (H) cannot be changed during operation.

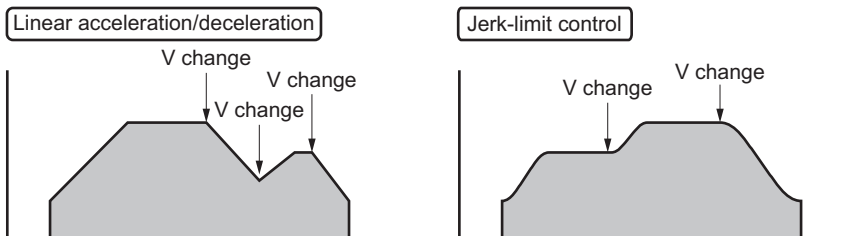

Memo If the motor has entered the +LS or -LS range, executing a SCAN command will allow the motor to pull out of the LS range. Once out of the LS range, the motor will stop immediately.

SEN

Name	Set the home-position detection mode		
Valid mode	Direct input/program		
Syntax	SEN (1 2) [, □] n		
	Parameter		Data range
	(1 2)	Axis	1 (select axis 1), 2 (select axis 2) If this parameter is omitted, axis 1 will be selected.
	n	Sensor mode	2 (2-sensor mode), 3 (3-sensor mode)
Function	Specifies the number of sensors installed in the system. Configure the setting to 2-sensor mode if \pm LS only, and to 3-sensor mode if HOMELS is present.		
Request	0>SEN1 0: SEN1 = 2 0>SEN2 0: SEN2 = 2		

■ About the home-position detection modes

There are two operation modes for mechanical home seeking: the 2-sensor mode (constant-speed operation) and the 3-sensor mode (high-speed operation).

Choose the mode according to the number of sensors installed in the system.

• 2-sensor mode

Uses two sensors, +LS and -LS, and returns to the mechanical home at the starting speed (VS).
Mechanical home will be either +LS or -LS.

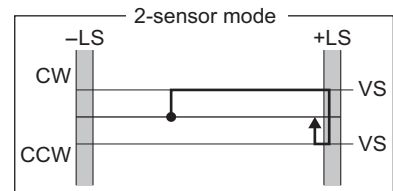

• 3-sensor mode

Uses three sensors: +LS, -LS and HOMELS. Since there are three sensors checking the location of the motor, high-speed return to the mechanical home position is possible regardless of the motor's position.
Under the three-sensor mode, HOMELS is the mechanical home position

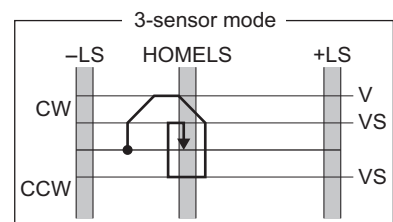

T

Name	Set acceleration/deceleration rate			
Valid mode	Direct input/program			
Syntax	T (1 2) [, □] n			
	Parameter		Data range	Default
	(1 2)	Axis	1 (select axis 1), 2 (select axis 2) If this parameter is omitted, axis 1 will be selected.	
	n	Acceleration/ deceleration rate	0.5 to 1000 ms/kHz (0.1 ms/kHz increments)	30
Function	Sets the acceleration/deceleration rate. The setting will be used for both acceleration and deceleration.			
Request	0>T1 0: T1 = 500 0>T2 0: T2 = 500			

TIM

Name	Set TIM. input and SLIT input			
Valid mode	Direct input/program			
Syntax	TIM. (1 2) [, □] n1 [, □] n2			
	Parameter		Data range	Default
	(1 2)	Axis	1 (select axis 1), 2 (select axis 2) If this parameter is omitted, axis 1 will be selected.	
	n1	TIM. input usage	0 (not used), 1 (used)	0
n2	SLIT input usage	0 (not used), 1 (used)	0	
Function	Sets whether the TIM. input and the SLIT input are used or not when executing mechanical home seeking.			
Request	0>TIM1 0: TIM1 = 0, 0 0>TIM2 0: TIM2 = 1, 0			

■ Setting the sub-sensors

Mechanical home seeking stops the motor in the proximity of the home position according to the signals from HOMEELS.

If the timing signal output from a driver and the slit signal output from a motor with a slit sensor are used in addition, more precise return to home operations can be achieved.

UNIT

Name	Set the unit of movement amount		
Valid mode	Direct input/program		
Syntax	UNIT (1 2) [, □] n1 [, □] n2		
	Parameter		Data range
	(1 2)	Axis	1 (select axis 1), 2 (select axis 2) If this parameter is omitted, axis 1 will be selected.
	n1	Movement amount per pulse (unit value)	0.0001 to 9.9999 (The number obtained by dividing the movement amount per revolution by the number of pulses per revolution*)
n2	Number of step angle divisions	1.0 to 255.0 (supports micro-step)	1.0
Function	Sets the unit of movement amount. Also sets the number of step angle divisions to support micro-step. Always set this parameter when using a driver that supports micro-step. After the movement amount is set, the current position will be set to 0.		
Request	0>UNIT1 0: UNIT1 = 1, 1		

* The value when the division of step angle is 1



Warning

Depending on the setting in the D command, the motor may rotate more than you had expected, causing a dangerous situation. When setting is performed with a UNIT command, always change (or check) the settings in the D command. The same goes for the OFS command.

■ Setting the movement-amount unit

For a positioning operation, the unit for the movement amount can be set to the movement distance or the rotational angle of the motor. By configuring the movement-amount unit, the movement amount can be set not only in pulses but in movement distance or in angles, making it easier to set the movement amount. Changing the movement-amount unit does not affect the operating speed.

$$\text{Unit value} = \frac{\text{Movement amount per motor revolution}}{\text{Number of pulses per motor revolution}^*}$$

*The value when the division of step angle is 1

When changing the movement-amount unit, the movement amount per pulse (unit value) must be calculated first.

The calculated unit value will be set with the UNIT command.

■ Movement unit and movement amount

When a UNIT command is set, the number of pulse outputs will change in accordance with the formula below:

Formula: Number of pulse outputs = $(D/n1) \times n2$

Note

When configured with a UNIT command, the number of fractional digits for the movement amount used in the D command will be the same as the number of fractional digits of the unit value.

Example: When the unit value is 0.1, the movement amount can be set to xxx.x (1 digit after the decimal point) in a D command.

Example: When the unit value is 0.01, the movement amount can be set to xxx.xx (2 digits after the decimal point) in a D command.

The current position will be cleared if a movement-amount unit is set.

Example)

Setting in angle

Basic step angle = 0.72° [500 pulses per motor revolution]

- Unit value when there is no gear and the micro-step function is not used (number of divisions is 1) = UNIT1, 0.72, 1
→ With D1 90, 125 pulses will be output.
- Unit value when there is no gear and the micro-step function is used (number of divisions is 10) = UNIT1, 0.72, 10
→ With D1 90, 1250 pulses will be output.

Basic step angle: $0.72/50 = 0.0144^\circ$

- Unit value when the gear ratio is 50:1 and the micro-step function is not used (number of divisions is 1) = UNIT1, 0.0144, 1
→ With D1 90, 6250 pulses will be output.

Setting in mm

Basic step angle = 0.72° and lead = 10 mm (UNIT value = $10 \text{ mm}/500 \text{ pulses} = 0.02$)

- Unit value when there is no gear and the micro-step function is not used (number of divisions is 1) = UNIT1, 0.02, 1
→ With D1 100, 5000 pulses will be output.
- Unit value when there is no gear and the micro-step function is used (number of divisions is 10) = UNIT1, 0.02, 10
→ With D1 100, 50000 pulses will be output.

Basic step angle: $0.02/50 = 0.0004^\circ$

- Unit value when the gear ratio is 50:1 and the micro-step function is not used (number of divisions is 1) = UNIT1, 0.0004, 1
→ With D1 100, 250,000 pulses will be output.

UPLD

Name	Upload		
Valid mode	Direct input		
Syntax	UPLD		
	Parameter	Data range	Default
	-		
Function	Uploads the sequence program saved in the controller into a specified file in the PC as a text file.		
Request	-		

V

Name	Set operating speed		
Valid mode	Direct input/program		
Syntax	V (1 2) [, □] n		
	Parameter		Data range
	(1 2)	Axis	1 (operate axis 1), 2 (operate axis 2) If this parameter is omitted, axis 1 will be operated.
n	Operating speed	10 to 200,000 Hz	10000
Function	Sets the operating speed. During a continuous operation, setting with a command during an operation becomes valid immediately, resulting in a multistep speed-change operation.		
Request	0>V1 0: V1 = 10000 0>V2 0: V2 = 20000		

VS

Name	Set starting speed		
Valid mode	Direct input/program		
Syntax	V (1 2) [, □] n		
	Parameter		Data range
	(1 2)	Axis	1 (operate axis 1), 2 (operate axis 2) If this parameter is omitted, axis 1 will be operated.
n	Starting speed	10 to 200,000 Hz	1000
Function	Sets the starting speed. This setting can be performed during an operation. However, the command setting will not be valid until the next operation.		
Request	0>VS1 0: VS1 = 1000 0>VS2 0: VS2 = 2000		

10 Controlling with the operational unit

This section covers how to change the data in the **EMP400** Series with the operational unit **OP300**.

10.1 Installing and connecting the operational unit

Install the operational unit on an appropriate flat metal plate having high resistance to vibration.

Use a metal plate with a thickness of 3 mm (0.12 in.) or less.

If the metal plate is thicker than 3 mm (0.12 in.), the modular connector on the supplied cable cannot be connected.

■ Location for installation

- Inside an enclosure that is installed indoors (provide vent holes)
- Operating ambient temperature 0 to +50 °C (+32 to +122 °F) (non-freezing)
- Operating ambient humidity 20 to 85% (non-condensing)
- Area that is free of explosive atmosphere or toxic gas (such as sulfuric gas) or liquid
- Area not exposed to direct sun
- Area free of excessive amount of dust, iron particles or the like
- Area not subject to splashing water (rains, water droplets), oil (oil droplets) or other liquids
- Area free of excessive salt
- Area not subject to continuous vibration or excessive shocks
- Area free of excessive electromagnetic noise (from welders, power machinery, etc.)
- Area free of radioactive materials, magnetic fields or vacuum

■ Installing the operational unit

Install operational unit from the front side of the mounting hole.

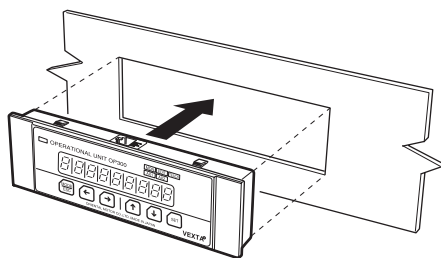

• Dimension of mounting hole [mm (in.)]

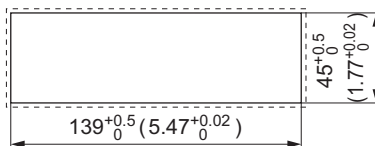

■ How to connect

Connection and disconnection of the operational unit must be performed before powering up the controller.

Note Be sure to turn on the controller power with the operational unit connected. To disconnect the operational unit, turn off the controller power and then unplug the cable. Connecting the operational unit with the controller power on will result in an error and the unit cannot be used.

Plug the supplied cable's modular connectors into the connector port on the operational unit and the CN2 terminal on the controller. When disconnecting the cable, pull out the cable while lightly pushing the tab on the modular connector.

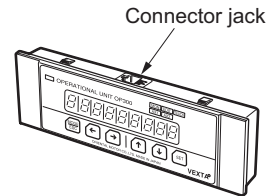

Note Be sure to use the cable provided. A communication cable for connecting to a PC (FC04W5) cannot be connected to the operational unit.

■ Removing the operational unit

1. Pull the cable's modular connector out of the operational unit.
2. To remove the unit, squeeze in the four hooks on the top and bottom of the back of the operational unit at the same time while pressing the unit toward the front.

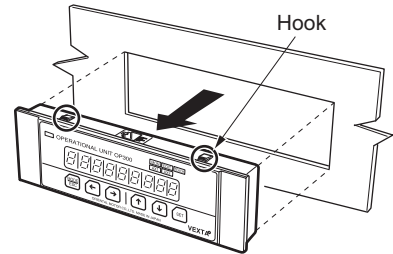

10.2 Basic operations

Operation specific to the operational unit will be described.

If this is the first time using the operational unit, please read and understand this section on basic operations and learn the operations specific to the operational unit before using it.

Names of parts

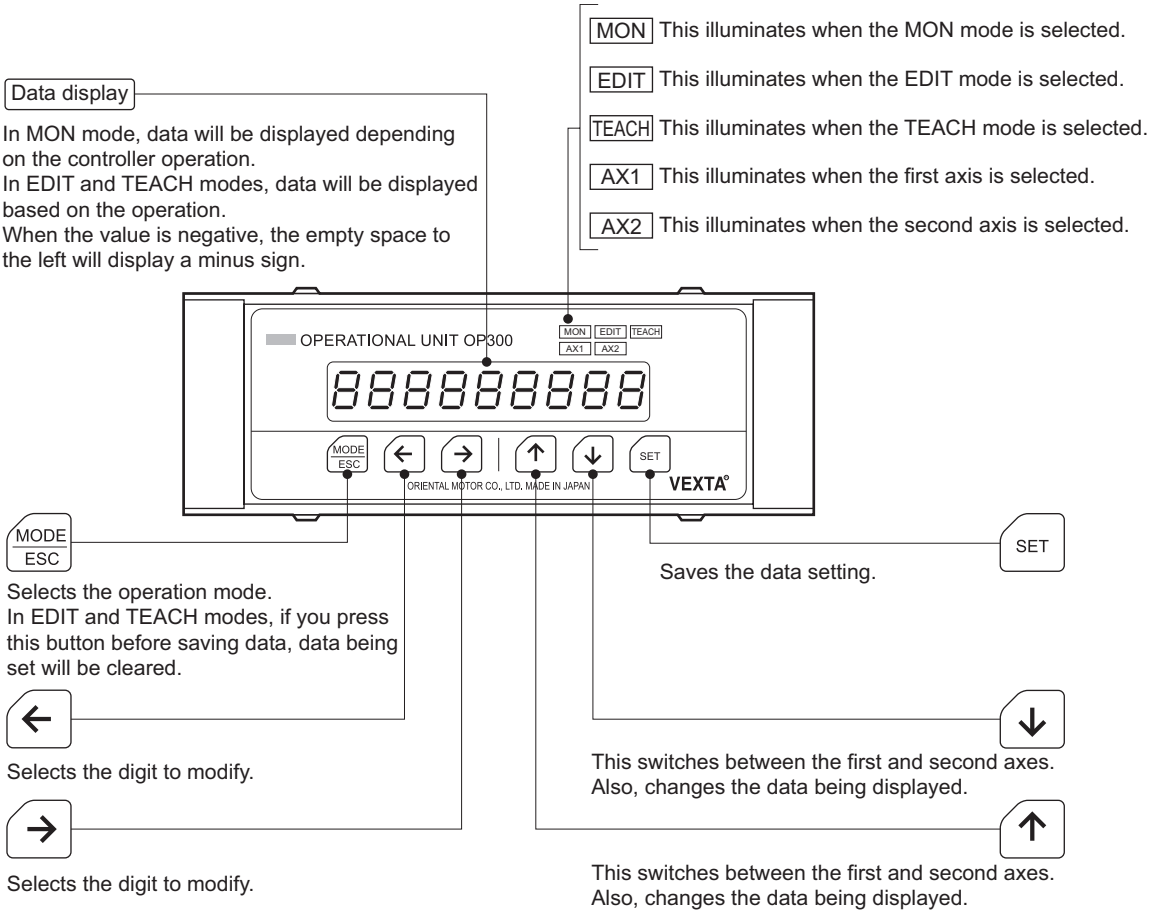

Switching between operation modes

The operational unit has three modes: monitor mode, edit mode and teaching mode.

Operation mode	LED	Description
Monitor mode	MON	This mode displays in real time the current position of the motor or the number of the sequence program under execution, along with the line number. This mode is automatically selected when the power is turned on.
Edit mode	EDIT	This mode can change the movement amount for D commands set in sequence programs.
Teaching mode	TEACH	This mode corrects the work position during a positioning operation or mechanical home seeking.

Press  to change the operation mode.



Every time  is pressed, the operation mode changes from the monitor mode to edit mode to teaching mode and the corresponding LED is illuminated.



Note

When a sequence program is running or when the motor is operating, the mode cannot be switched to edit mode or teaching mode in order to prevent a malfunction.

Entering and saving numeric values

The data display of the operational unit displays an eight-digit number. Each digit refers to one numeric character that is displayed.

The value of the blinking digit can be changed. Use  or  to increment or decrement the number.

To change the digit to be edited, use  or  to move the blinking to the adjacent digit.

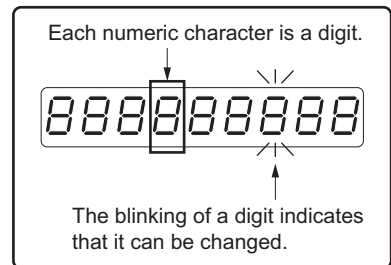

Move the editing digit to the right. 

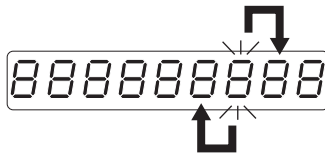



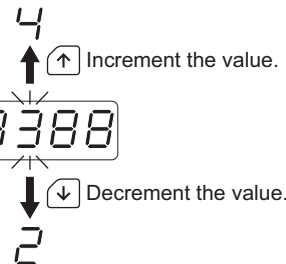

Move the editing digit to the left. 



After checking the input value, press  so that the controller will memorize the data.

Memo



Pressing and holding  or  does not change the digit repeatedly. Press the button several times, if necessary.

If  is pressed before  is pressed, the input value will be cleared without being stored in the controller.

Entering the sign

OP300 allows entering of + and – signs.

Signs can be entered as the leftmost digit. Move the blinking cursor to the left and press \leftarrow or \rightarrow to choose the display corresponding to the sign.

Sign	Display	Meaning
When +		Motor rotates in the CW direction
When –		Motor rotates in the CCW direction
No sign change		Rotational direction set in the sequence program

Entering a numeric value with a decimal point

When entering a value that includes a decimal point, such as the movement amount, the following procedure must be taken.

Up to seven digits after the decimal point can be entered. The total number of digits that can be entered, including the digits after the decimal point, is 8.

1. Press \rightarrow to move the blinking cursor to the lowest (rightmost) digit.
2. Confirm that the blinking is at the lowest and rightmost digit, then press \rightarrow .
A decimal point and the first digit after the decimal point will be displayed, while the highest (leftmost) digit is deleted.

Note

- When digits after the decimal point are displayed, the highest digit is deleted.
- If you make an incorrect entry, press \leftarrow to revert to the original value.

3. Enter the numeric value using \uparrow and \downarrow .
To enter more than one digit after the decimal point, move the blinking cursor to the lowest digit and press \rightarrow . The next digit will be displayed while the highest digit is deleted.
To delete the digits after the decimal point, move the blinking cursor to the position where the sign is and press \leftarrow . The lowest (rightmost) digit is deleted and the highest digit will be displayed to the left end.

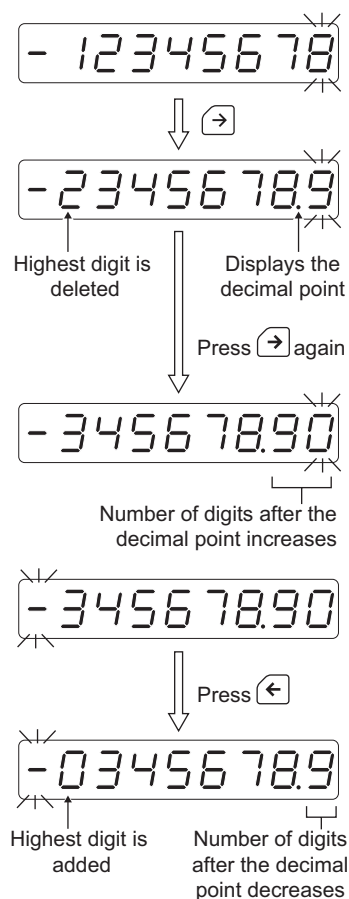

10.3 Monitor mode

In monitor mode, the current position of the motor will be displayed in real time.

Displays the current position LED for axis 1 LED for axis 2

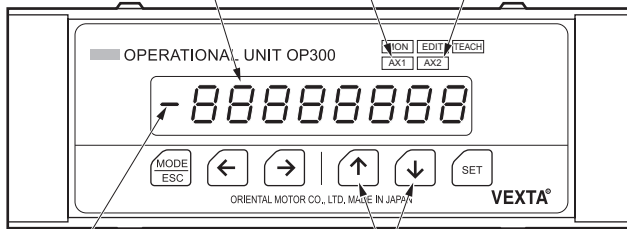

Displays the sign

Switches between axes 1 and 2

When the power of the operational unit is turned on, the unit automatically displays the current position of axis 1 and illuminates the AX1 LED. If the movement-amount unit has been set with the UNIT command, the display will be in movement units. If the value is negative, the space to the left will display a minus sign.

In monitor mode, every time \uparrow or \downarrow is pressed, the current positions for axis 1 and axis 2 are displayed in turn, illuminating their respective LEDs.

If you press \leftarrow or \rightarrow , the number of the sequence program under execution and the line number will be displayed. To return to the current position display, press \uparrow or \downarrow .

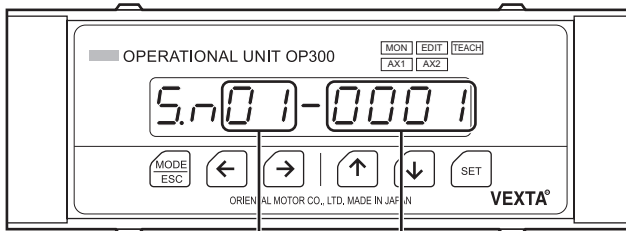

Sequence program number

Line number





10.4 Edit mode

In edit mode, the movement amount for D commands set in sequence programs can be changed.

Note To prevent a malfunction, the host controller cannot operate the motor in edit mode.







■ Operation

1. Be sure the sequence program is not running.
2. Press  to switch to edit mode.
The data display will show “Ed00-0000” and the digit before the hyphen will blink.
The EDIT LED will illuminate.

3. Increment or decrement the value with  or  and move through the digits using  or  to select the number of the sequence program whose movement amount is to be changed and the step number in which the movement amount for the D command is set.
Enter the sequence program number as the two digits before the hyphen in “Ed00-0000” and the line number as the four digits after the hyphen.

4. Press  after entering the sequence program number and the line number.
The movement amount set in the D command will be displayed. The rightmost digit will blink.

Memo If the movement amount is not set in the specified line in the sequence program, “not found” will be displayed for one second, after which the control will return to step 3.

5. Change the movement amount by changing the value with  or  and move through the digits with  or .
To enter the sign, select the empty space to the left (the blinking will stop) and set the sign with  or .

Memo See section “Entering the sign” on how to enter a sign on p.90.

6. Press  after changing the movement amount.
The updated value will be used as the new movement amount in the sequence program.

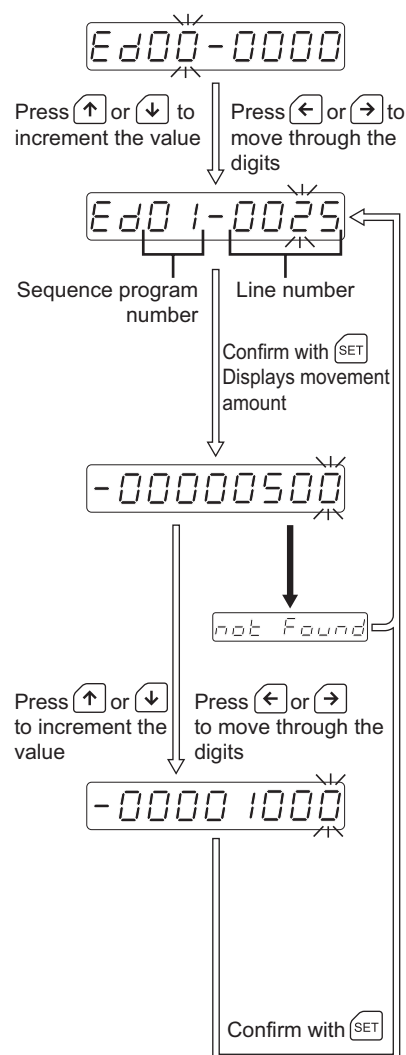

10.5 Teaching mode

Note To prevent a malfunction, the host controller cannot operate the motor in teaching mode.

The teaching mode actually consists of the following four modes:

Mode name	Description
Teaching mode	In this mode the work is actually moved in order to update the movement amount for a D command set in a sequence program.
HOME mode	This mode performs mechanical home seeking.
Step execution mode	In this mode the work position is corrected while running a sequence program.
Speed setting mode	In this mode the starting speed, operating speed and acceleration/deceleration rate during teaching are set. However, the setting data is valid for teaching, mode, and HOME mode; it does not affect sequence programs.



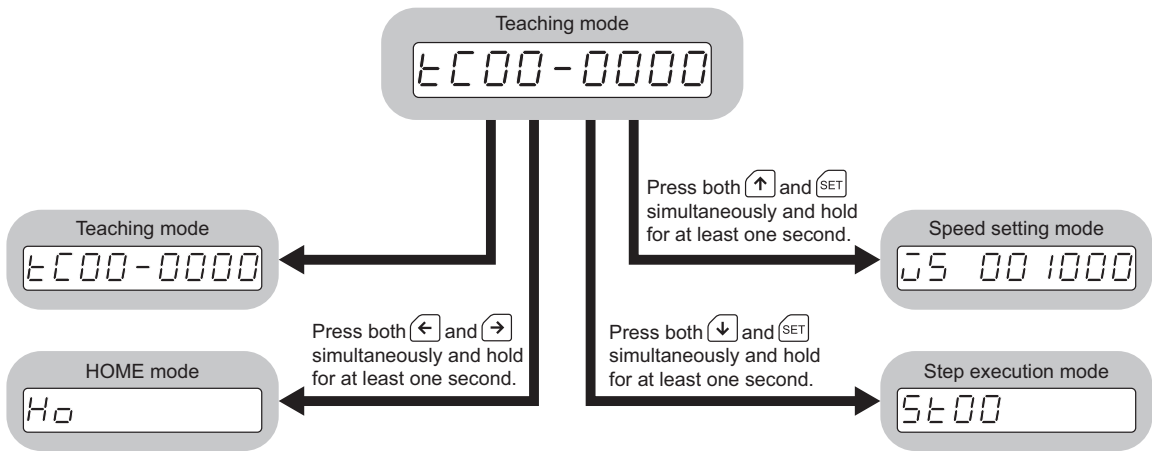



Each mode can be entered after selecting the teaching mode.











Operation in teaching mode



Work is actually moved in order to update the movement amount for a D command set in a sequence program.

■ Operation

1. Be sure the sequence program is not running.
2. Press  to switch to teaching mode.
The data display will show “tC00-0000” and the digit before the hyphen will blink.
The TEACH LED will illuminate.
3. Select the number of the sequence program on which teaching is to be performed and the line number in which the movement amount for the D command is set.
Increment or decrement the value with  or  and move through the digits using  or  to enter the sequence program number as the two digits before the hyphen in “tC00-0000” and the line number as the four digits after the hyphen.
4. Press  after entering the sequence program number and the line number.
The current position will be displayed.

Memo | If the movement amount is not set in the specified line in the sequence program, “not found” will be displayed for one second, after which the control will return to step 3.

5. Move the work with  or  to correct the position.
The data display will show the work position in real time.
If  or  is held down for one second or more, continuous operation at the starting speed will be performed as long as the key is held down.
If  is pressed while a continuous operation is performed by holding down  or , continuous operation at the operating speed will be performed as long as  key is held down.
6. Press  after the work position has been corrected.
The updated position will be used as the new movement amount in the sequence program.

Memo | In the teaching mode, the motor will stop immediately upon entering the +LS or -LS range. Pressing  or  will allow the motor to pull out of the LS range.

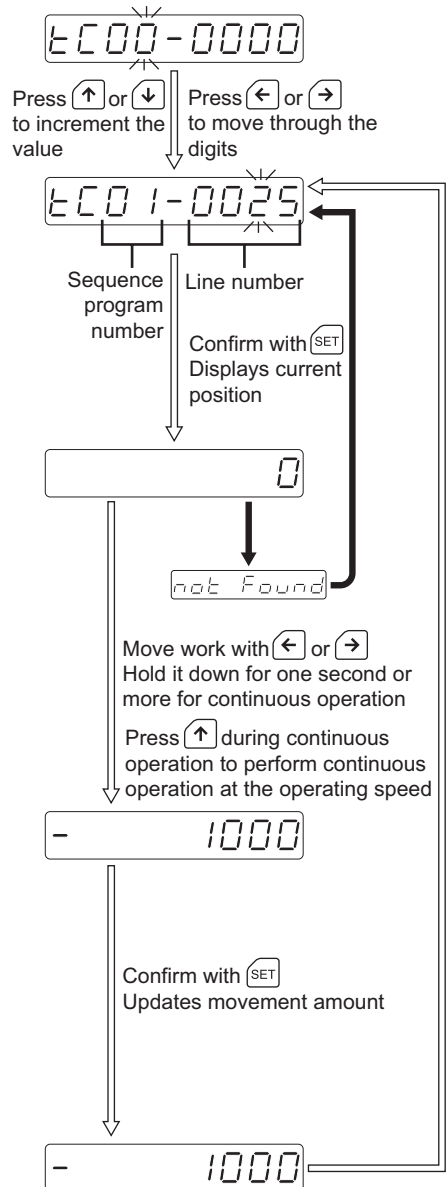







Operation in HOME mode

The operational unit can be used to perform mechanical home seeking.

This is a convenient function if mechanical home seeking is necessary prior to teaching.

The home detection mode (SEN), home offset (OFS), rotational direction (H) and TIM./SLIT input setting (TIM) will conform to the last settings.

■ Operation

1. Be sure the sequence program is not running.
2. Press  to switch to teaching mode.
The data display will show “tC00-0000” and the digit before the hyphen will blink.
The TEACH LED will illuminate.
3. Press  and  simultaneously and hold them down for at least one second to switch to HOME mode.
The data display will show “Ho.”
4. With  and , select the axis on which mechanical home seeking is to be performed.
If the first axis is selected, the AX1 LED will illuminate.
If the second axis is selected, the AX2 LED will illuminate.
5. Press  after selecting the axis.
The data display will show “Ho.StArt.”
6. Press  one more time.
Mechanical home seeking starts and the data display will show the work position in real time.
Once mechanical home seeking is complete, the data display will show “Ho End.”

Memo | To stop mechanical home seeking, press .
The motor will decelerate to a stop.

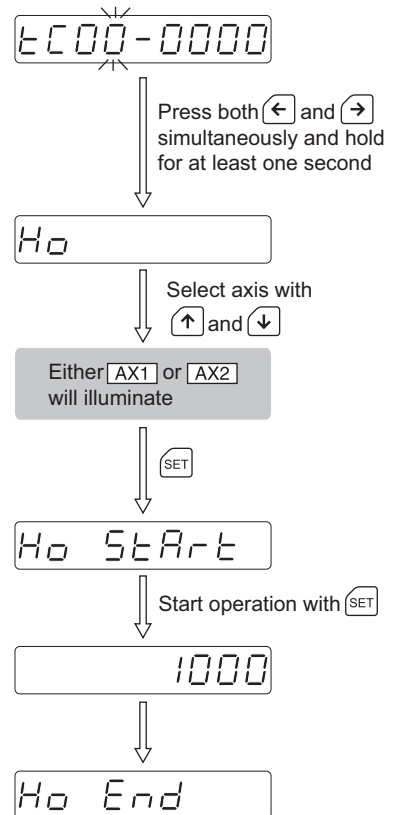

Operation in step execution mode

Step execution mode comes in handy when teaching a sequence program with multiple operation commands (ABS commands, INC commands).

In step execution mode, the selected sequence program is executed one line at a time when **SET** is pressed. The movement amount can be adjusted after executing a line with an operation command. By repeating this procedure, teaching can be performed while running a sequence program.

Note To prevent a malfunction, the host controller cannot operate the motor in step execution mode.

■ Operation



1. Be sure the sequence program is not running.
2. Press **ABS** to switch to teaching mode.
The data display will show “tC00-0000” and the digit before the hyphen will blink.
The TEACH LED will illuminate.
3. Press **↓** and **SET** simultaneously and hold them down for at least one second to switch to step execution mode.
The data display will show “St00.”
4. Enter the number of the sequence program to which the step execution mode is to be applied.
Increment or decrement the value with **↑** or **↓** and move through the digits using **←** or **→** to select the sequence program number.
5. Press **SET** after entering the sequence program number.
The data display will show the sequence program number and line number.

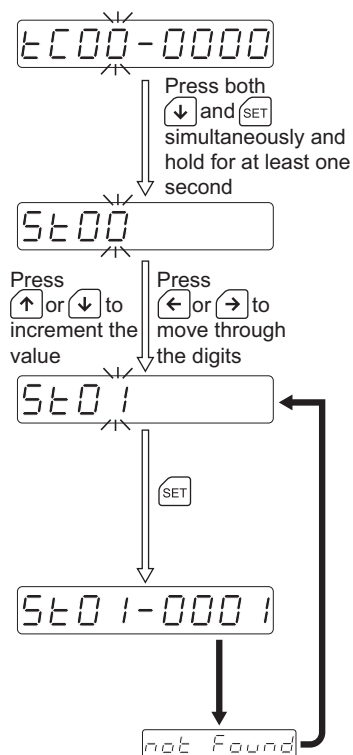

Memo If the specified sequence program number does not exist, “not found” will be displayed for one second, after which the control will return to step 4.



6. Press .

The line displayed will be executed.
The display during command execution is as shown below:



Command	Display
DELAY	Countdown for time setting
IN	Displays "In" until the condition is met
ABS INC SCAN MHOME	Current position of the operating axis (During a 2-axis linear interpolation operation, the current position of axis 1 is displayed. Pressing  or  switches to axis 2.)
Others	Current position of axis 1





7. After executing a positioning operation, press  and  simultaneously and hold them down for at least one second.

For incremental operation, the relative movement amount will be displayed. For absolute operation, the current position will be displayed. This allows the work position to be corrected.

8. Move the work with  or  to correct the work position.



The data display will show the work position in real time.

If  or  is held down for one second or more, continuous operation at the starting speed will be performed as long as the key is held down.

If  is pressed while a continuous operation is performed by holding down  or , continuous operation at the operating speed will be performed as long as  key is held down.

9. Press  after the work position has been corrected.

The updated position will be used as the new movement amount in the sequence program. The number of the next line will be displayed. During a 2-axis linear interpolation operation, this will be followed by the display of the current position of axis 2, allowing teaching for axis 2.

Memo To teach on axis 1 again after teaching axis 2, press  and  simultaneously and hold them down for at least one second. Teaching for the selected step can restart from the beginning.
Press  to abort from step execution mode.

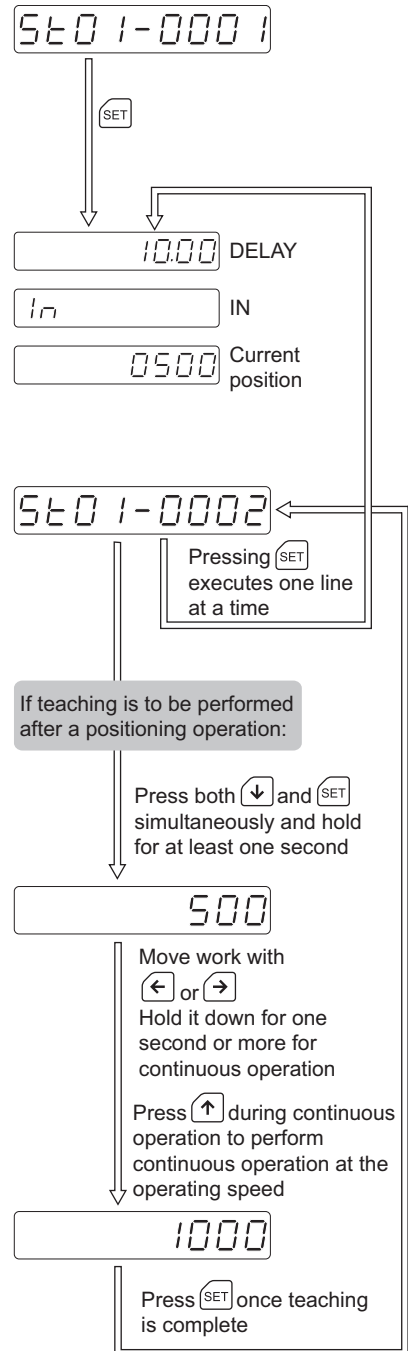

Operation in speed setting mode

The starting speed, operating speed and acceleration/deceleration rate during teaching are set. The setting data is valid for teaching, mode, and HOME mode. It does not affect sequence programs.

The specified speed data will revert to the initial values once the power is reconnected.

The initial value is 1000 [Hz] for the starting speed, 10000 [Hz] for the operating speed, and 30 [ms/kHz] for the acceleration/deceleration rate.

■ Operation

1. Be sure the sequence program is not running.
2. Press to switch to teaching mode.
The data display will show “tC00-0000” and the digit before the hyphen will blink.
The TEACH LED will illuminate.
3. Press and simultaneously and hold them down for at least one second to switch to speed setting mode.
The data display will show the current starting speed setting.
4. Select starting speed, operating speed or acceleration/deceleration rate with or .
5. With or , select the axis for which the speed data is to be set.
Selecting axis 1 will illuminate the AX1 LED, while selecting axis 2 will illuminate the AX2 LED.
6. Press after selecting the axis.
The data display will show the current speed data and the rightmost digit will start to blink.
7. Update speed data.
Increment or decrement the value with or and move through the digits using or to change the speed data.
8. Press after updating speed data.
New data will apply to the operational unit as new speed data.

If no other speed data is to be changed, press to switch to teaching mode.

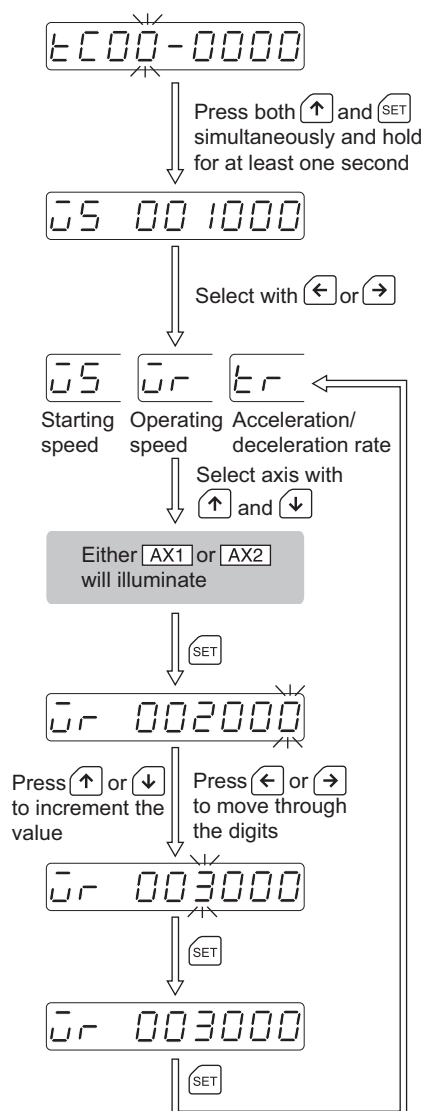

10.6 Quick chart

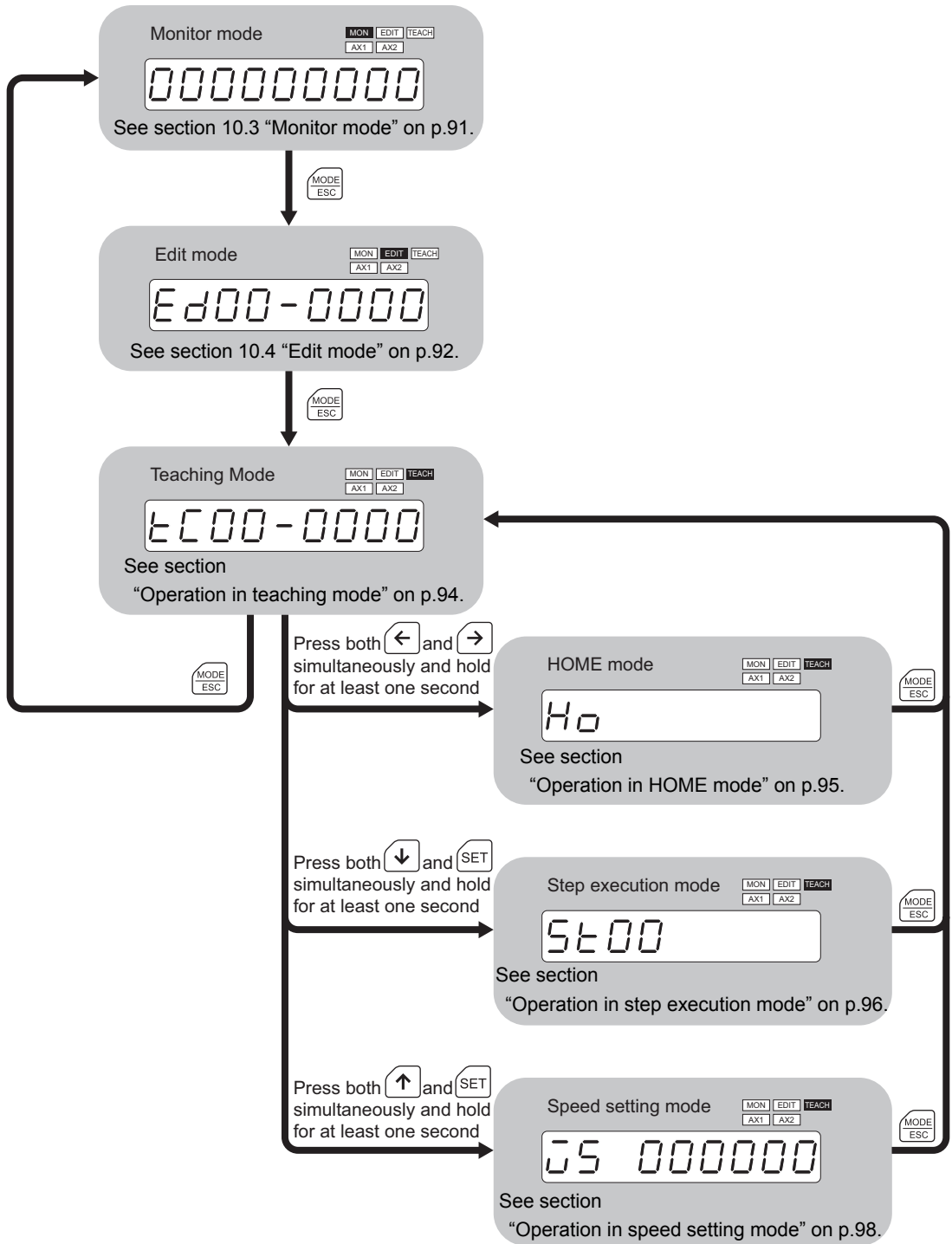

10.7 Error display

The section below explains the errors displayed by the **OP300**.

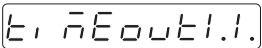
Error display	
Description	Communication between the EMP400 Series and the OP300 could not be performed normally.
Remedial action	While the OP300 is connected to the EMP400 Series, turn off the power to the EMP400 Series and turn it on again.

11 Troubleshooting

This section covers how to handle problems that may arise during motor operation and sequence program execution.

11.1 When the ALARM LED illuminates

When an alarm is generated, the ALM output turns on and the ALARM LED on the controller illuminates. If an alarm is generated, check the error message displayed on the PC HyperTerminal. Refer to section 11.2 “Error messages” on p.103, and respond accordingly.

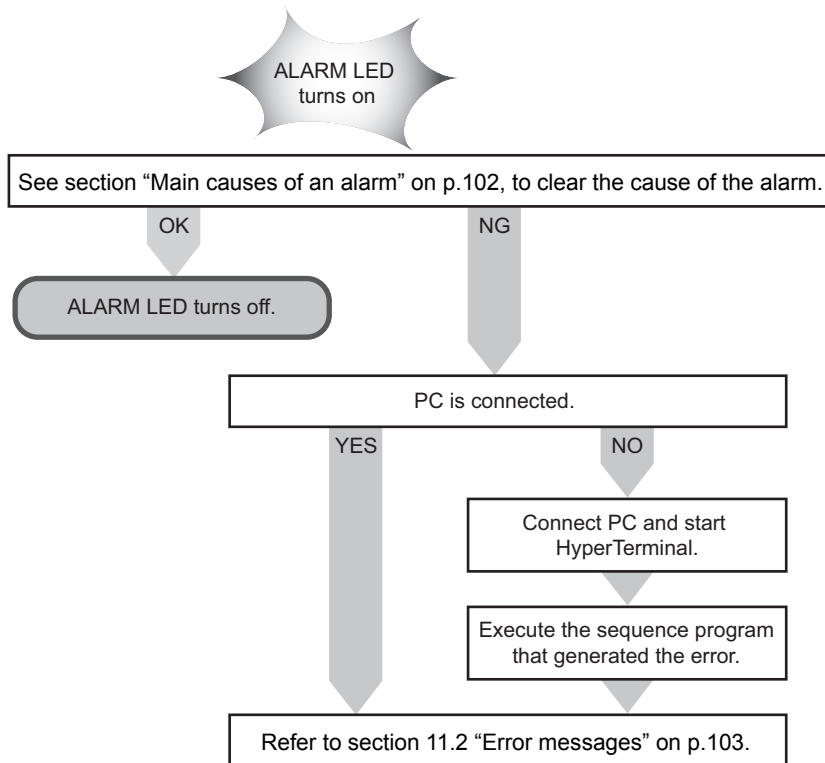

Main causes of an alarm

When the ALARM LED turns on, check for the following conditions. If none of the following conditions applies, check the error message displayed on the HyperTerminal.

Cause	Remedial action
E-STOP input is turned off.	See "E-STOP switch active." in section 11.2 "Error messages" on p.105.
ALM or limit-sensor output logic for the driver does not match the output logic of the controller.	Set the output logic for each signal, depending on the specifications for the driver and limit sensor. (See ACTL command.)
ALM input is on.	See "Driver alarm" in section 11.2 "Error messages" on p.104.
The limit sensor is on.	See "CW limit switch active," "CCW limit switch active" and "CW-CCW limit switch active" in section 11.2 "Error messages" on p.104.
The operation parameter setting is not executable.	Correct the commands and input parameters in the sequence program.

11.2 Error messages

When setting data or when operating the motor, error messages may be displayed on the HyperTerminal. When an error message is displayed, check the status of the controller and motor.

Error message	Meaning	Possible cause and remedial action	Reference
Can not Overwrite	The sequence program already exists, and the program cannot be overwritten.	Specify a different sequence program or delete the current program, and then download again.	DWNLD command
Command disable while executing.	<ul style="list-style-type: none"> • Unacceptable command has been received from the HyperTerminal while executing the sequence program. An error message will be displayed but the sequence program will not stop. • Description in the sequence program is incorrect. Operation command, ID command or UNIT command is detected between a SCAN command and a command that stops continuous operation. The motor decelerates to a stop and the sequence program stops. • The START input turned on when a sequence program was being executed. • An operation command was input from HyperTerminal when a sequence program was being executed. • An operation command was input from HyperTerminal when the READY output was off. 	<ul style="list-style-type: none"> • Enter a correct command. • Correct the sequence program. • Turn on the START input after the sequence program is completed. • Input the operation command after the sequence program is completed. • To abort the sequence program, turn on the S-STOP input or press the ESC key on the PC keyboard. • Check if the START input remains on. 	
Command is not allowed in immediate mode.	A command that cannot be entered directly has been received.	Enter a command that can be entered directly.	
Command is not allowed in program mode.	The command entered from the sequence program is not executable. A command that cannot be entered via a sequence program exists in the sequence program.	Enter commands that can be entered from a sequence program.	

Error message	Meaning	Possible cause and remedial action	Reference
CW limit switch active.	<p>This is a limit-sensor error. The sequence program stops (stops immediately during pulse output).</p> <ul style="list-style-type: none"> • +LS input is turned on while the motor is in operation. • Operation command has been entered when +LS input is on. 	<p>Perform mechanical home seeking or a continuous operation.</p> <p>Mechanical home seeking returns to the mechanical home position.</p> <p>Continuous operation starts an operation in the rotational direction opposite to the stopped LS regardless of the rotational direction setting. The operation stops when the control escapes the LS.</p> <p>Check if the output logic of the LS used matches that of the controller.</p>	ACTL command
CCW limit switch active.	<p>This is a limit-sensor error. The sequence program stops (stops immediately during pulse output).</p> <ul style="list-style-type: none"> • -LS input is turned on while the motor is in operation. • Operation command has been entered when -LS input is on. 	<p>Perform mechanical home seeking or a continuous operation.</p> <p>Mechanical home seeking returns to the mechanical home position.</p> <p>Continuous operation starts an operation in the rotational direction opposite to the stopped LS regardless of the rotational direction setting. The operation stops when the control escapes the LS.</p> <p>Check if the output logic of the LS used matches that of the controller.</p>	ACTL command
CW•CCW limit switches active.	<p>Limit-sensor input logic setting error. +LS input and -LS input both are turned on at the same time.</p> <p>The sequence program stops (stops immediately during pulse output).</p>	<p>LS output logic for the controller does not match that of the LS being used.</p> <p>Change the output logic for the LS.</p> <p>If this error message is displayed when \pmLS is at contact B, check for disconnection on the LS.</p>	ACTL command
Driver alarm.	<p>An alarm from the driver. The sequence program stops (decelerates to a stop during pulse output).</p> <ul style="list-style-type: none"> • The driver alarm input turned on when the motor was operating. • An operation command was input when the driver alarm input was on. 	<ul style="list-style-type: none"> • An anomaly has occurred at the driver. Check the operating condition of the motor or ventilate and cool the driver. Refer to the operating manual for your driver. • If the driver is not in the alarm state, check to see if the alarm output logic of the driver matches that of the controller. 	ACTL command

Error message	Meaning	Possible cause and remedial action	Reference
E-STOP switch active.	E-STOP input has been turned off. The sequence program stops (stops immediately during pulse output).	<ul style="list-style-type: none"> • Turn the E-STOP input to "On" (current supplied). • Check the connections. 	Section "Internal input circuit" on p.20.
ENDL without LOOP.	The numbers of LOOP commands and ENDL commands in the sequence program did not match.	Correct the sequence program so that one LOOP command corresponds to one ENDL command.	LOOP command ENDL command
HOME sequence error.	<p>Mechanical home seeking did not proceed as planned. The sequence program stops (decelerates to a stop during pulse output).</p> <ul style="list-style-type: none"> • +LS input, -LS input and HOMELS input are all turned on at the same time. • HOMELS input did not turn on in a 3-sensor home detection. • -LS or +LS has been detected while operating in the CW or CCW direction, respectively. 	<ul style="list-style-type: none"> • The positions of +LS and -LS are too close to the position of HOMELS. Separate HOMELS from ±LS so that ±LS and HOMELS do not turn on at the same time. • Check the connection between the controller and ±LS/HOMELS. If the connection is correct: Confirm that the detection range of HOMELS is at least 10 ms. If the connection is incorrect: Connect HOMELS. When HOMELS is not used: Select the 2-sensor mode. If the shielding plate is longer than the distance between HOME LS and +LS or between HOME LS and -LS, reverse the starting direction of home detection. 	SEN command
Interpolation error.	During the execution of 2-axis linear interpolation operation, the speed of the sub-axis, calculated from the main axis, exceeded the setting range.	Correct the starting speed, operating speed or acceleration/deceleration rate.	
Invalid value.	<p>Invalid setting value error. The sequence program stops (decelerates to a stop during pulse output).</p> <ul style="list-style-type: none"> • A value outside the setting range has been set. • The number of fractional digits differed between the unit value and movement amount. 	Enter the correct value.	

Error message	Meaning	Possible cause and remedial action	Reference
Line dose not exist.	The specified line number does not exist in the sequence program. The sequence program stops (decelerates to a stop during pulse output).	Check the line number and enter the correct line number.	
Missing ENDL.	The numbers of LOOP commands and ENDL commands in the sequence program did not match.	Correct the sequence program so that one LOOP command corresponds to one ENDL command.	LOOP command ENDL command
Missing parameter.	The input command is missing a mandatory parameter.	Enter the command and its parameters.	
NVRAM sequences checksum error.	There is at least one corrupted parameter in the controller memory.	<ul style="list-style-type: none"> Sequence program or ID data of the controller has been corrupted because power was lost while writing data into the EEPROM. Delete all sequence programs and ID data, then reenter the sequence program. Data could not be written correctly due to EEPROM life. (The number of writes that can be performed on an EEPROM is limited to 100,000 writes.) 	
Out of memory.	The number of lines in the sequence program exceeded 1000. Controller memory is not available and new data cannot be entered with the edit command.	Change the number of sequence program lines to 1000 lines or less.	
Overtime waiting for END	The END signal output from the driver was not input to the controller within one second. The sequence program stops (decelerates to a stop during pulse output).	<ul style="list-style-type: none"> This indicates a possible motor overload. If connected to a driver without END output signal, change the controller setting to "Does not use END signal." <p>Control recovers automatically when a sequence program or operation is restarted.</p>	EEN command

Error message	Meaning	Possible cause and remedial action	Reference
Position counter overflow. Please clear Position counter.	Counter overflow. Absolute positioning operation has been attempted at a position outside the manageable coordinates. The sequence program stops (decelerates to a stop during pulse output).	Reset the counter using one of the following methods: <ul style="list-style-type: none"> • Execute mechanical home seeking. • Clear the counter (reset counter to 0) with a RESET command. • Clear the current position (reset counter to 0) with a RTNCR command. 	RESET command RTNCR command
Rx buffer overflow!	The number of characters in a single line exceeds 80 (including comment).	Reduce the number of characters in a single line to 80 or less (including comment).	
Sequence dose not exist.	The sequence program number specified by the command does not exist.	Check the sequence program number.	
S-STOP switch active.	An operation command has been input or an attempt to run the sequence program was made while the S-STOP input was on.	Turn off the S-STOP input.	
Syntax error.	There is a mistake in the entered command.	Enter the correct command.	
TIMING (or SLIT) signal is not within HOME active region.	TIM. input/SLIT input detection error. Neither TIM. input nor SLIT input has been detected during mechanical home seeking. The sequence program stops (decelerates to a stop during pulse output).	<ul style="list-style-type: none"> • Adjust the point where the motor's output shaft and the load shaft meets or adjust the HOMEELS position so that TIM. input and SLIM input turns on while HOMEELS is on. • If TIM. input and SLIT input are not used, change the controller setting to "Does not use TIM. input/SLIT input. Control recovers automatically when a sequence program or operation is restarted.	TIM command
Too many nested LOOPS.	The number of nested loops exceeded the maximum of 4. The sequence program stops (decelerates to a stop during pulse output).	Change the number of nested loops to four or less.	

12 Sample programs

This section covers examples of basic sequence programs for the **EMP400**.

12.1 Operation by the host controller

IN1 input of CN1: Accepts signals from the host controller

END output of CN1: Sends signals to the host controller

■ Sample sequence program

[1] PULSE1 2	Sets the pulse output mode to 2-pulse mode
[2] ETIME 50	Sets the END output time to 50 ms
[3] T1 30.0	Sets the acceleration/deceleration rate to 30 ms/kHz
[4] VS1 500	Sets the starting speed to 500 Hz
[5] V1 10000	Sets the operating speed to 10000 Hz
[6] IN 1, 1	Waits until IN1 input is on
[7] D1 2000	Set the movement amount to 2000
[8] H1 +	Sets the rotational direction to CW
[9] INC1	Executes an incremental positioning operation

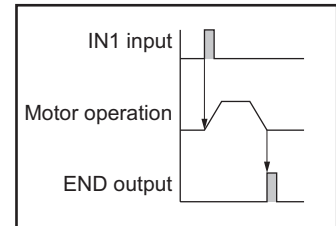

12.2 Speed change operation by the host controller

IN1 input of CN1: Accepts signals from the host controller

■ Sample sequence program

[1] PULSE1 2	Sets the pulse output mode to 2-pulse mode
[2] T1 30.0	Sets the acceleration/deceleration rate to 30 ms/kHz
[3] VS1 500	Sets the starting speed to 500 Hz
[4] V1 10000	Sets the operating speed to 10000 Hz
[5] H1 +	Sets the rotational direction to CW
[6] SCAN1	Execute continuous operation
[7] IN 1, 1	Waits until IN1 input is on
[8] V1 2000	Sets the operating speed to 2000 Hz

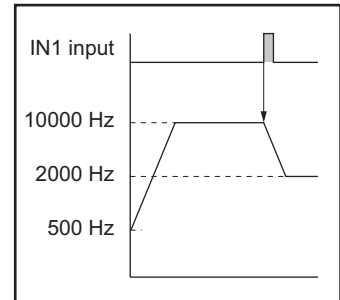

To stop a continuous operation, enter an S command or turn the S-STOP input on.

12.3 Speed change operation at a specified time

■ Sample sequence program

- | | |
|--------------|--|
| [1] PULSE1 2 | Sets the pulse output mode to 2-pulse mode |
| [2] T1 30.0 | Sets the acceleration/deceleration rate to 30 ms/kHz |
| [3] VS1 500 | Sets the starting speed to 500 Hz |
| [4] V1 1000 | Sets the operating speed to 1000 Hz |
| [5] H1 + | Sets the rotational direction to CW |
| [6] SCAN1 | Execute continuous operation |
| [7] DELAY 1 | Sets the delay to 1 second |
| [8] V1 2000 | Sets the operating speed to 2000 Hz |
| [9] DELAY 2 | Sets the delay to 2 seconds |

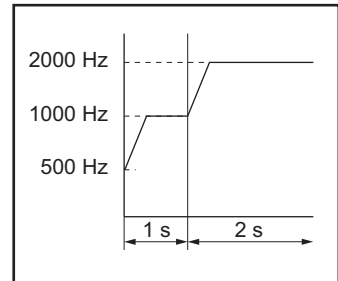

To stop a continuous operation, enter an S command or turn the S-STOP input on.

12.4 Repeating positioning operations

When movement amount is set in pulses

Motor to be used: **AS46AA**

Movement amount per pulse: 0.36 degrees

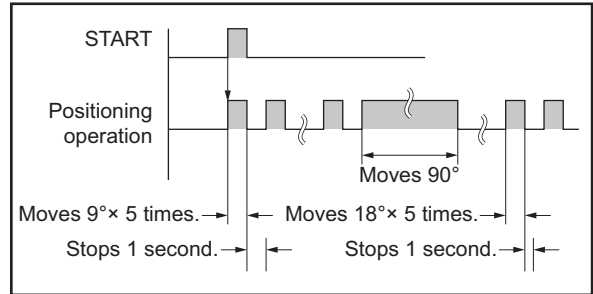
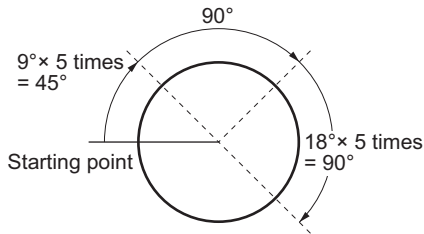

[1] PULSE1 2	Sets the pulse output mode to 2-pulse mode
[2] UNIT 1, 1	Sets the unit of movement amount to pulses
[3] T1 50	Sets the acceleration/deceleration rate to 50 ms/kHz
[4] VS1 500	Sets the starting speed to 500 Hz
[5] V1 1200	Sets the operating speed to 1200 Hz
[6] H1 +	Sets the rotational direction to CW
[7] MHOME1	Executes mechanical home seeking
[8] LOOP 5	Repeats steps 8 through 12 five times
[9] D1 25	Sets the amount of movement to 25 pulses (rotates 9 degrees)
[10] INC1	Executes incremental positioning operation
[11] DELAY 1	Sets the delay to 1 second
[12] ENDL	End of loop
[13] D1 250	Sets the amount of movement to 250 pulses (rotates 90 degrees)
[14] INC1	Executes incremental positioning operation
[15] LOOP 5	Repeats steps 15 through 19 five times
[16] D1 50	Sets the amount of movement to 50 pulses (rotates 18 degrees)
[17] DELAY 1	Sets the delay to 1 second
[18] INC1	Executes incremental positioning operation
[19] ENDL	End of loop

When movement amount is set in degrees

Motor to be used: **AS46AA**

Since one revolution of a motor is 360 degrees, if the number of pulses per motor revolution is 1000, then

Unit value = $360 \text{ degrees} / \text{Number of pulses per revolution} = 0.36$

[1] PULSE1 2	Sets the pulse output mode to 2-pulse mode
[2] UNIT 0.36, 1	Sets the unit of movement amount to degrees
[3] T1 50	Sets the acceleration/deceleration rate to 50 ms/kHz
[4] VS1 500	Sets the starting speed to 500 Hz
[5] V1 1200	Sets the operating speed to 1200 Hz
[6] H1 +	Sets the rotational direction to CW
[7] MHOME1	Executes mechanical home seeking
[8] LOOP 5	Repeats steps 8 through 12 five times
[9] D1 9	Sets the amount of movement to 9-degree rotation
[10] INC1	Executes incremental positioning operation
[11] DELAY 1	Sets the delay to 1 second
[12] ENDL	End of loop
[13] D1 90	Sets the amount of movement to 90-degree rotation
[14] INC1	Executes incremental positioning operation
[15] LOOP 5	Repeats steps 15 through 19 five times
[16] D1 18	Sets the amount of movement to 18-degree rotation
[17] DELAY 1	Sets the delay to 1 second
[18] INC1	Executes incremental positioning operation
[19] ENDL	End of loop

When movement amount is set in mm

Motorized linear slides to be used: **SPF60B10-1SD**

If the movement amount per motor revolution is 10 mm and the number of pulses per motor revolution is 1000, then

Unit value = 10 mm/Number of pulses per revolution = 0.01

The rotational directions of the motor and the axis are the same.

[1] PULSE1 2	Sets the pulse output mode to 2-pulse mode
[2] UNIT 0.01, 1	Sets the unit of movement amount to mm
[3] T1 50	Sets the acceleration/deceleration rate to 50 ms/kHz
[4] VS1 500	Sets the starting speed to 500 Hz
[5] V1 1200	Sets the operating speed to 1200 Hz
[6] H1 +	Sets the rotational direction to CW
[7] MHOME1	Executes mechanical home seeking
[8] LOOP 5	Repeats steps 8 through 12 five times
[9] D1 5	Sets the amount of movement to 5 mm
[10] INC1	Executes incremental positioning operation
[11] DELAY 1	Sets the delay to 1 second
[12] ENDL	End of loop
[13] D1 15	Sets the amount of movement to 15 mm
[14] INC1	Executes incremental positioning operation
[15] LOOP 5	Repeats steps 15 through 19 five times
[16] D1 2	Sets the amount of movement to 2 mm
[17] DELAY 1	Sets the delay to 1 second
[18] INC1	Executes incremental positioning operation
[19] ENDL	End of loop

12.5 Conditional jump procedure

If IN1 input of CN1 turns on, mechanical home seeking is executed.

If IN2 input of CN1 turns on, an incremental system positioning operation is executed.

■ Sample sequence program

[1] CJMP 1, 1, 4	Jumps to line 4 if bit 1 is on
[2] CJMP 2, 1, 10	Jumps to line 10 if bit 2 is on
[3] JMP 1	Jumps to line 1
[4] VS1 1000	Sets the starting speed to 1000 Hz
[5] V1 3000	Sets the operating speed to 3000 Hz
[6] H1 +	Sets the rotational direction to CW
[7] T1 10	Sets the acceleration/deceleration rate to 10 ms/kHz
[8] MHOME1	Executes mechanical home seeking
[9] END	End of sequence program
[10] VS 1000	Sets the starting speed to 1000 Hz
[11] V1 3000	Sets the operating speed to 3000 Hz
[12] H1 +	Sets the rotational direction to CW
[13] T1 10	Sets the acceleration/deceleration rate to 10 ms/kHz
[14] D1 3000	Sets the amount of movement to 3000
[15] INC1	Executes incremental positioning operation
[16] END	End of sequence program

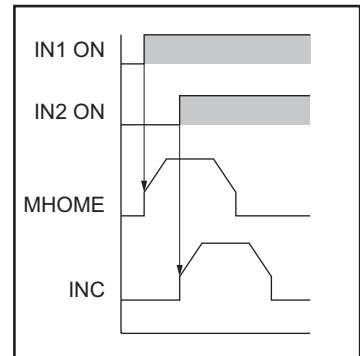

13 Options (sold separately)

■ Operational unit

This tool is used for monitoring the current position, correcting data and performing teaching when the motor is driven using the **EMP400** Series.

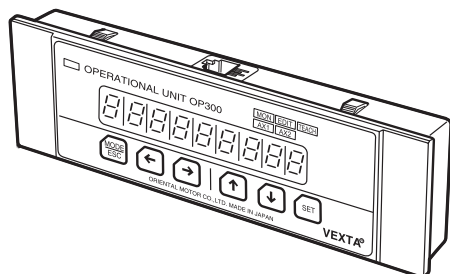

Model: **OP300** (Cable supplied)

■ Driver/controller connection cable

One end of this shielded cable has a half-pitch connector that can be quickly connected to a driver, while the other end has a dedicated **EMP400** Series connector.

• α STEP, DiMER

Model	Length
CC01EMP4	1 m (3.3 ft.)
CC02EMP4	2 m (6.6 ft.)

• RK Series

Model	Length
CC01EMP5	1 m (3.3 ft.)
CC02EMP5	2 m (6.6 ft.)

■ Connector-terminal block conversion unit

Use this cable to connect the **EMP400** Series to a host controller via the terminal block.

Model	Length
CC50T1	1 m (3.3 ft.)

- Unauthorized reproduction or copying of all or part of this Operating Manual is prohibited.
If a new copy is required to replace an original manual that has been damaged or lost, please contact your nearest Oriental Motor branch or sales office.
- Characteristics, specifications and dimensions are subject to change without notice.
- While we make every effort to offer accurate information in the manual, we welcome your input. Should you find unclear descriptions, errors or omissions, please contact the nearest office.
- **Oriental motor** is a trademark of Oriental Motor Co., Ltd.
αSTEP is a trademark of Oriental Motor Co., Ltd., and is registered in Japan and other countries.
Other product names and company names mentioned in this manual may be trademarks or registered trademarks of their respective companies and are hereby acknowledged. The third-party products mentioned in this manual are recommended products, and references to their names shall not be construed as any form of performance guarantee. Oriental Motor is not liable whatsoever for the performance of these third-party products.

© Copyright ORIENTAL MOTOR CO., LTD. 2006

- Please contact your nearest Oriental Motor office for further information.

ORIENTAL MOTOR U.S.A. CORP.
Technical Support Line Tel:(800)468-3982
 Available from 7:30 AM to 5:00 PM, P.S.T.
 E-mail: techsupport@orientalmotor.com
 www.orientalmotor.com

ORIENTAL MOTOR (EUROPA) GmbH
Headquarters and Düsseldorf Office
 Tel:0211-5206700 Fax:0211-52067099
Munich Office
 Tel:08131-59880 Fax:08131-598888
Hamburg Office
 Tel:040-76910443 Fax:040-76910445

ORIENTAL MOTOR (UK) LTD.
 Tel:01256-347090 Fax:01256-347099

ORIENTAL MOTOR (FRANCE) SARL
 Tel:01 47 86 97 50 Fax:01 47 82 45 16

ORIENTAL MOTOR ITALIA s.r.l.
 Tel:02-93906346 Fax:02-93906348

TAIWAN ORIENTAL MOTOR CO., LTD.
 Tel:(02)8228-0707 Fax:(02)8228-0708

SINGAPORE ORIENTAL MOTOR PTE. LTD.
 Tel:(6745)7344 Fax:(6745)9405

ORIENTAL MOTOR (MALAYSIA) SDN. BHD.
 Tel:(03)79545778 Fax:(03)79541528

INA ORIENTAL MOTOR CO., LTD.
KOREA
 Tel:(032)822-2042~3 Fax:(032)819-8745

ORIENTAL MOTOR CO., LTD.
Headquarters Tokyo, Japan
 Tel:(03)3835-0684 Fax:(03)3835-1890